

# IP 20 distributed inputs/outputs Advantys OTB

Catalogue  
April

# 05





# IP 20 distributed inputs/outputs Advantys OTB

---

## Distributed I/O system for network or fieldbus

*Selection guide* ..... pages 2 and 3

- Presentation, description ..... page 4
- Characteristics ..... pages 5 and 6
- References ..... page 7
- Dimensions, schemes ..... page 8
- Mounting ..... page 9

## Discrete I/O modules

*Selection guide* ..... pages 10 to 13

- Presentation, description ..... page 14
- Characteristics ..... page 15
- References ..... pages 16 and 17
- Dimensions, connections ..... pages 18 to 21

## Analogue I/O modules

*Selection guide* ..... pages 22 and 23

- Presentation, description ..... page 24
- Characteristics ..... pages 25 and 26
- References, dimensions ..... page 27
- Connections ..... pages 28 and 29

## Telefast® pre-wired system for I/O modules

*Selection guide* ..... pages 30 and 31

- Presentation, description ..... pages 32 to 34
- Compatibility ..... page 35
- Characteristics ..... pages 36 and 37
- Curves ..... pages 38 and 39
- References, dimensions ..... pages 40 and 41
- Schemes ..... pages 42 to 45

# IP 20 distributed inputs/outputs

Distributed I/O system for network or fieldbus  
Advantys OTB

<b>Applications</b>	<b>Data exchange between a control source (PLC, variable speed drives, PC, etc.) and the inputs and outputs</b>
<b>Type of bus or network</b>	Ethernet TCP/IP network



<b>Nature of bus or network</b>	Mixed local industrial network
<b>Structure</b>	Physical interface
	Access method
	Transfer rate
	10/100 BASE-T (RJ 45 connector)
	CSMA-CD
	10/100 Mbits/s

<b>Medium</b>	Shielded dual twisted pair via Ethernet ConneXium cabling system
<b>Configuration</b>	Number of devices
	Maximum length (distance)
<b>Digital inputs/outputs</b>	Number of I/O
	Number of inputs
	Number of outputs
	256 max. per network segment. Unlimited using switches.
	500 m according to standard 802.3
	1000 m with ConneXium cabling system
	20 I/O
	12 --- 24 V sink/source (PNP or NPN) inputs
	6 relay outputs and 2 --- 24 V transistor, source (PNP) outputs

<b>Type of connection</b>	Removable screw terminal blocks
---------------------------	---------------------------------

<b>Input/output expansion</b>	Number of expansion modules
	Maximum I/O configuration
	7 digital or analogue input/output modules, or connection accessories
	With interface module:
	- 132 with screw/spring terminal digital I/O expansion module,
	- 244 with type HE10 connector digital I/O expansion module,
	- up to 48 analogue I/O (24 input channels and 24 output channels)

<b>Supply voltage</b>	--- 24 V supply
-----------------------	-----------------

<b>Integrated I/O functions</b>	Counting, 5 kHz
	or Counting, 20 kHz
	Pulse generator, 7 kHz
	2 channels, 32 bits (0...4 294 967 295 points)
	- dedicated digital inputs
	- up/down counting with preset value
	2 channels, 32 bits (0...4 294 967 295 points)
	- dedicated digital inputs/outputs
	- up/down counting, up counting, down counting, frequency meter
	2 PWM function channels (output with pulse width modulation) and PLS function (pulse generator output)

<b>Type</b>	<b>OTB 1E0 DM9LP</b>
-------------	----------------------

<b>Page</b>	7
-------------	---

**Data exchange between a control source (PLC, variable speed drives, PC, etc.) and the inputs and outputs**

CANopen bus	Modbus Series network
-------------	-----------------------



CAN fieldbus	Local RS 485 network
ISO 11898 (SUB-D 9-pin connector)	RS 485 (2 x RJ 45 connectors in parallel)
CSMA-MA, multimaster	Master-slave
10...1000 Kbits/s depending on distance	1.2...38.4 kbauds

Shielded dual twisted pair	Dual twisted pair
127 slaves	32 slaves per segment
From 30 m (1 Mbits/s) to 1000 m (> 50 Kbits)	Up to 1000 m

20 I/O
12 --- 24 V sink/source (PNP or NPN) inputs
6 relay outputs and 2 --- 24 V transistor, source (PNP) outputs

Removable screw terminal blocks

7 digital or analogue input/output modules, or connection accessories

With interface module:  
 - 132 with screw/spring terminal digital I/O expansion module,  
 - 244 with type HE10 connector digital I/O expansion module,  
 - up to 48 analogue I/O (24 input channels and 24 output channels)

--- 24 V supply

2 channels, 32 bits (0...4 294 967 295 points)  
 - dedicated digital inputs  
 - up/down counting with preset value

2 channels, 32 bits (0...4 294 967 295 points)  
 - dedicated digital inputs/outputs  
 - up/down counting, up counting, down counting, frequency meter

2 PWM function channels (output with pulse width modulation) and PLS function (pulse generator output)

<b>OTB 1C0 DM9LP</b>	<b>OTB 1S0 DM9LP</b>
----------------------	----------------------

7	7
---	---



622008

### Presentation

There is an increasing tendency for machine manufacturers to design their automation systems using modular architectures. The use of distributed inputs/outputs (I/Os) is becoming more and more common. The Advantys OTB offer is an ideal solution for “optimised” type distributed input/output requirements. This offer, complementing the Advantys interface family, has been designed to provide the right technical-economical balance: it meets the needs of machine manufacturers and users seeking the best compromise between size, ease of cabling, setting-up and costs. Open and modular, the Advantys OTB solution enables the creation of industrial I/O islands managed by a master controller (PLC, PC or variable speed drive) via a fieldbus or communication network.

With its expandable block type architecture, the Advantys OTB solution adapts to all configurations of automation system islands. The Advantys OTB offer is particularly economical for small and medium size islands. In addition, the optimised sizes of this offer are ideally suited to the size of enclosures for distributed I/Os, that are located as near to the machine as possible. This solution reduces cabling time and costs and at the same time takes into account the modular architecture of the machine.

Furthermore, the Advantys OTB offer proposes fewer references relating to spare parts and accessories that are required for creating an island.

The Advantys OTB offer has also been designed to be as simple as possible. This offer includes 3 communication bases (interface modules) for the various types of network or fieldbus: Ethernet TCP/IP/Modbus, CANopen or Modbus RS 485 Serial Line. Inputs and outputs are directly integrated in the interface modules. Each base incorporates 20 I/O:

- 12  $\pm$  24 V inputs,
- 6 relay outputs,
- 2  $\pm$  24 V solid-state outputs.

All the bases use a  $\pm$  24 V supply. Of monobloc design, each Advantys OTB interface module can be fitted with expansion modules.

With its range of I/O expansions, the Advantys OTB offer provides a modularity that allows all requirements to be met, commencing with a base that can be fitted with up to 7 digital or analogue I/O modules. The expansion modules, like the interface modules, simply clip-on to 35 mm symmetrical rail and enable configurations of up to 132 digital I/O and up to 48 analogue I/O channels, or a mixture of both types (within the limit of 7 expansion modules), to be obtained.

Sensors and actuators are connected to the interface modules and I/O expansion modules using removable screw terminal blocks. All Advantys OTB modules provide an IP 20 degree of protection. To simplify sensor and actuator connections, as well as linking commons, the Advantys OTB offer also includes a commoning module. This module, as with all the other modules of the Advantys OTB range, allows the through connection of the internal bus or network (passively in this case) and enables connection of the commons in two isolated groups for each commoning module.

### Description

The Advantys OTB 1●0 DM9LP (1) interface modules comprise:

- 1 An access door to the speed and network address coding wheels.
- 2 A connector for expansion modules (right-hand side).
- 3 Two or three coding wheels (depending on model) for island address and bus or network communication speed adjustment.
- 4 Indicator lights (communication status and I/O states).
- 5 Screw terminal connectors for connection of inputs/outputs.
- 6 Connectors for connection of bus or communication network.
- 7 Terminals for connection of  $\pm$  24 V supply.

Mounting: the interface modules mount on 35 mm symmetrical rail.

(1) Only the communication part is dedicated to each fieldbus or network and can differ, the general description remains the same.

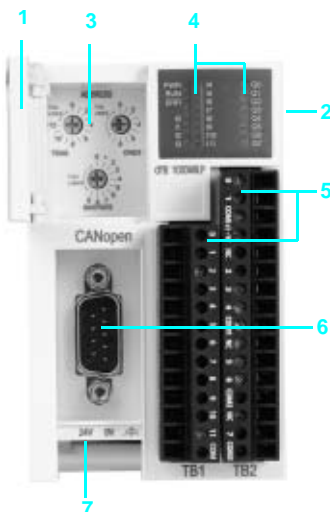

Environmental characteristics				
<b>Product certifications</b>			cULus, CE	
<b>Temperature</b>	Operation	°C	0...+ 55	
	Storage	°C	- 25...+ 70	
<b>Relative humidity</b>			30...95%, without condensation	
<b>Degree of protection</b>			IP 20	
<b>Degree of pollution</b>	Conforming to IEC 60664		Type 2	
<b>Altitude</b>	Operation	m	0...2000	
	Storage	m	0...3000	
<b>Vibration resistance</b>		Hz	10...57, amplitude 0.075 mm, acceleration 57...150 Hz	
		m/s <sup>2</sup>	9.8 (1 gn)	
<b>Shock resistance</b>	Conforming to IEC 61131	m/s <sup>2</sup>	147 (15 gn), for 11 ms	
<b>Resistance to electrostatic discharges</b>	Conforming to IEC 61000-4-2	kV	4 on contact, 8 in air	
<b>Resistance to radiated fields</b>	Conforming to IEC 61000-4-3	V/m	10	
<b>Immunity to fast transient currents</b>	Conforming to IEC 61000-4-4	kV	0.5 for the I/Os, 1 for the --- 24 V supply	
<b>Mounting</b>			On 35 mm symmetrical rail	
Interface module characteristics				
Interface module type		OTB 1E0 DM9LP	OTB 1C0 DM9LP	OTB 1S0 DM9LP
<b>Type of bus/network</b>		Ethernet TCP/IP Modbus	CANopen	Modbus RS 485 Serial line
<b>Transmission</b>	Transfer rate	10 or 100 Mbits/s	10 Kbits/s...1 Mbits/s	1.2...38.4 kbauds
	Medium	Dual twisted pair, ConneXium	Shielded dual twisted pair	Dual twisted pair
<b>Structure</b>	Type	10/100 BASE-T	EN 50325 ISO 11898	Modbus.org
	Method	CSMA-CD	CSMA-MA, multimaster with priority	Master-slave
<b>Configuration</b>	Maximum number of devices	256 max. per segment, unlimited using switches	127	32 per segment
	Maximum length of bus/network	m	500 (1000 with ConneXium)	30 (1 Mbits/s) 5000 (10 Mbits/s)
<b>Type of port (bus/network connector)</b>		RJ 45	SUB-D (DB9)	2 x RJ 45 (in parallel)
<b>Power supply</b>	Nominal	--- V	24, non isolated	
	Voltage limits	--- V	20.4...26.4 including ripple	
	Maximum input current	mA	700 (at 26.4 V)	
	Maximum inrush current	A	50	
	Consumption	W	19 (interface module with 7 I/O expansion modules)	
<b>Number of --- 24 V inputs</b>			12	
<b>Number and type of outputs</b>			6 relay 2 solid-state, source (PNP)	
<b>Input/output connections</b>			Removable screw terminal block	
<b>Input/output expansion</b>	Maximum number of modules		7	
	Maximum number of I/O		- 132 with screw/spring terminal digital I/O expansion module, - 244 with type HE10 connector digital I/O expansion module, - up to 48 analogue I/O (24 input channels and 24 output channels)	
Integrated functions				
<b>Counting</b>	Number of channels		4	
	Frequency	kHz	5 x 2 channels or 20 x 2 channels (depending on configuration)	
	Capacity		32 bits x 2 channels	
<b>Movement</b>	Number of channels		2	
	Frequency	kHz	7	
	Functions		PWM (output with pulse width modulation), PLS (pulse generator output)	

## Input characteristics

<b>Number of input channels</b>			12
<b>Nominal input voltage</b>		$\text{--- V}$	24, sink or source (positive or negative logic, PNP or NPN)
<b>Common</b>			1
<b>Input voltage limits</b>		$\text{--- V}$	20.4...26.4
<b>Nominal input current</b>		<b>mA</b>	5 for I0 and I1, I6 and I7; 7 for the others
<b>Input impedance</b>		<b>k<math>\Omega</math></b>	5.7 for I0 and I1, I6 and I7; 3.4 for the others
<b>Electronic filtering time</b>	At state 1	$\mu\text{s}$	35 for I0 and I1, I6 and I7; 40 for the others
	At state 0	$\mu\text{s}$	45 for I0 and I1, I6 and I7; 150 for the others
<b>Configurable filtering time</b>			- electronic filtering time
		<b>ms</b>	- 3 or 12 depending on configuration
<b>Isolation</b>		$\sim \text{V}$	500 rms. No isolation between channels, isolation with internal logic using photocouplers

## Transistor output characteristics (solid-state)

<b>Number of output channels</b>			2
<b>Output logic</b>			Source (positive logic, PNP)
<b>Common</b>			1
<b>Nominal output values</b>	Voltage	$\text{--- V}$	24
	Current	<b>A</b>	0.3
<b>Output value limits</b>	Voltage	$\text{--- V}$	20.4...28.8
	Current per channel	<b>A</b>	0.36
	Current per common	<b>A</b>	0.72
<b>Response time</b>	At state 1	$\mu\text{s}$	5 for Q0 and Q1; 300 for other outputs
	At state 0	$\mu\text{s}$	5 for Q0 and Q1; 300 for other outputs
<b>Voltage drop</b> (voltage at state 1)		$\text{--- V}$	1 max.
<b>Maximum inrush current</b>		<b>A</b>	1
<b>Leakage current</b>		<b>mA</b>	0.1
<b>Induction L/R</b>		<b>ms</b>	10 (28.8 V $\text{---}$ , 1 Hz)
<b>Overvoltage protection</b>		$\text{--- V}$	39 $\pm$ 1
<b>Maximum power</b> (filament lamp)		<b>W</b>	8
<b>Isolation</b>		$\sim \text{V}$	500 rms. No isolation between channels, isolation with internal logic using photocouplers

## Relay output characteristics

<b>Number of output channels</b>			6
<b>Commons</b>	Common 1		3 contacts (relay) NO
	Common 2		2 contacts (relay) NO
	Common 3		1 contact (relay) NO
<b>Nominal output values</b> (1) (resistive or inductive load)	Voltage	$\text{--- V}$	30
		$\sim \text{V}$	240
	Current per channel	<b>A</b>	2
	Current per common	<b>A</b>	8
<b>Minimum switchable load</b>		<b>mA/--- V</b>	0.1 (reference value)
<b>Contact resistance</b> (unused condition)		<b>m<math>\Omega</math></b>	30 max.
<b>Insulation voltage</b> (rms)		$\sim \text{V}$	1500 for 1 minute
<b>Consumption for all the outputs</b>	At state 1	$\text{--- 5 V}$	<b>mA</b> 30
		$\text{--- 24 V}$	<b>mA</b> 40
	At state 0	$\text{--- 5 V}$	<b>mA</b> 5
<b>Electrical durability</b>	In AC-1		10 <sup>5</sup> operating cycles with 500 VA load
	In AC-14		10 <sup>5</sup> operating cycles with 250 VA load
	In AC-15		10 <sup>5</sup> operating cycles with 200 VA load
	In DC-1		10 <sup>5</sup> operating cycles with 60 W load
	In DC-13		10 <sup>5</sup> operating cycles with 30 W load

## Commoning block characteristics

<b>Commoning block type</b>			<b>OTB 9ZZ 61JP</b>
<b>Application</b>			Passive, inter-module
<b>Commons</b>			2 groups of 10 terminals
<b>Nominal output values</b> (1) (resistive or inductive load)	Voltage	$\text{--- V}$	19...30
		$\sim \text{V}$	215...240
	Current per channel	<b>A</b>	2
	Current per group of commons	<b>A</b>	8

(1) With 1800 operations max./hour:  
- electrical life: 100 000 operations min.,  
- mechanical life: 20 x 10<sup>6</sup> operations min.



# IP 20 distributed inputs/outputs

## Distributed I/O system for network or fieldbus

### Advantys OTB



OTB 1E0 DM9LP



OTB 1C0 DM9LP



OTB 1S0 DM9LP

#### Interface modules with integrated digital I/O

Supply voltage	Number and type of			Number of commons by	Connection	Fieldbus or network	Reference	Weight
	inputs	solid-state outputs	relay outputs	I/SO/RO (1)				kg
≡ 24 V	12 I	2 O	6 O	1/1/3	Removable screw terminal block	Ethernet TCP/IP/Modbus	<b>OTB 1E0 DM9LP</b>	0.185
	≡ 24 V IEC type 1	≡ 24 V 0.3 A	≡ 30 V / ~ 240 V 2 A			CANopen	<b>OTB 1C0 DM9LP</b>	0.195
						Modbus RS 485 Serial line	<b>OTB 1S0 DM9LP</b>	0.190

#### Separate components

Description	Usage	Number of commons	wires	Reference	Weight
<b>Commoning module</b>	For grouping input or output commons, 8 A maximum; inter-module	2 isolated groups	2 x 10	<b>OTB 9ZZ 61JP</b>	0.100
<b>Software and documentation</b>	Configuration software "Advantys Configuration, Tool-Lite" and hardware user guides	–	–	<b>FTX ES00</b>	0.050

#### Accessories

Description	Usage	Type of connector	Length m	Unit reference	Weight
<b>End of line adaptors (sold in lots of 2)</b>	For end of RS 485 line, R = 120 Ω, C = 1 nF	RJ 45	–	<b>VW3 A8 306 RC</b>	0.200
<b>"T" tap-offs, Modbus</b>		1 x RJ 45 male and 2 x RJ 45 female	0.3	<b>VW3 A8 306 TF03</b>	–
			1.0	<b>VW3 A8 306 TF10</b>	–
<b>Connection cables for Modbus bus Serial line</b>	RJ 45 connection (with screw or spring connector) Point-to-point connection	1 x RJ 45 one end, free wires other end 2 x RJ 45	3.0	<b>VW3 A8 306 D30</b>	0.150
			0.3	<b>VW3 A8 306 R03</b>	0.050
			1.0	<b>VW3 A8 306 R10</b>	0.050
<b>Shielded dual twisted pair cables</b>	RS 485	Without connector	100	<b>TSX CSA 100</b>	–
			200	<b>TSX CSA 200</b>	–
			500	<b>TSX CSA 500</b>	–

(1) Input, Solid-state Output, Relay Output.

## Dimensions

### OTB 1●0 DM9LP

Mounting on symmetrical 35 mm  $\sqcap$  rail

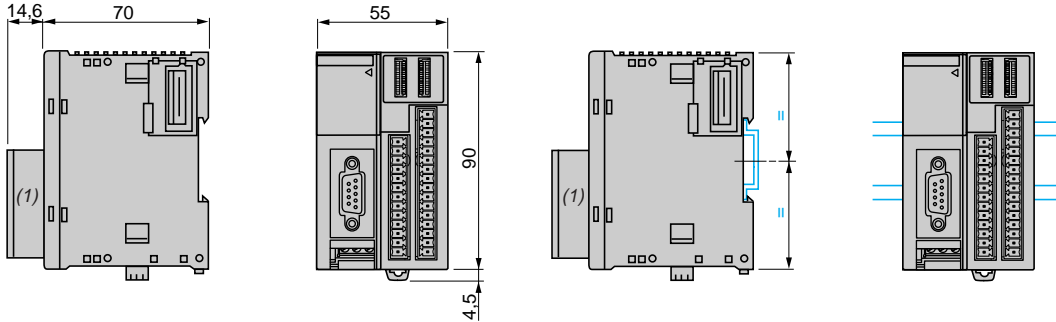

(1) With removable screw terminal block type connector.

### OTB 9ZZ 61JP

Mounting on symmetrical 35 mm  $\sqcap$  rail

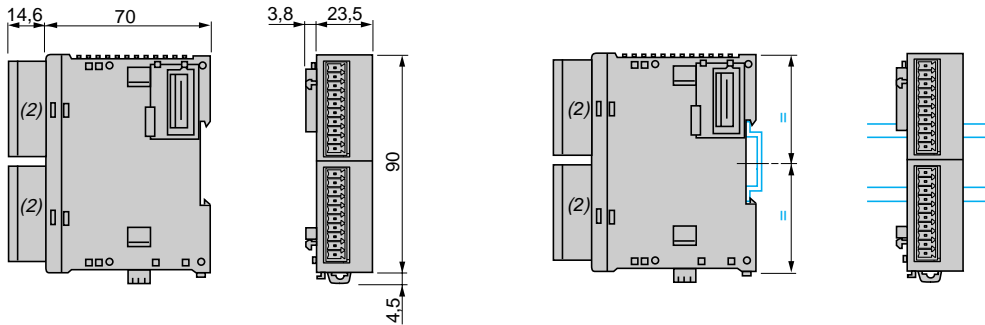

(2) With removable screw terminal block type connectors.

## Schemes

### OTB 1●0 DM9LP

### OTB 9ZZ 61JP

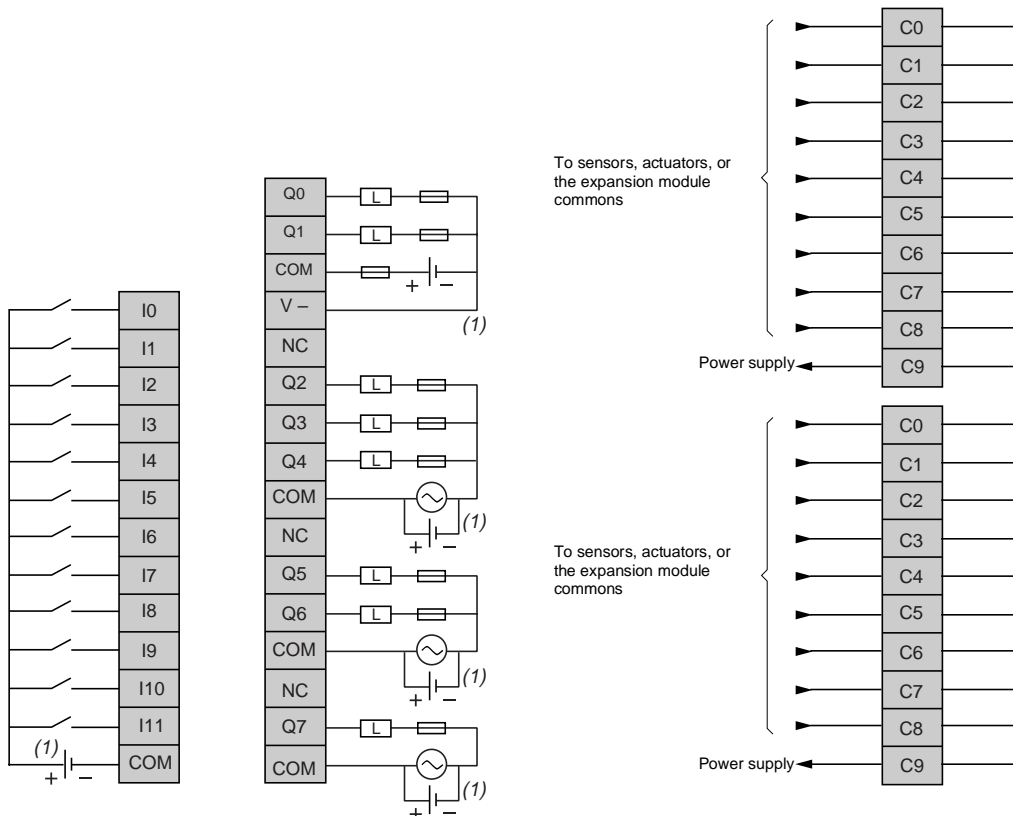

(1) Supply connection for sink inputs, source outputs (positive logic).

### Installation rules

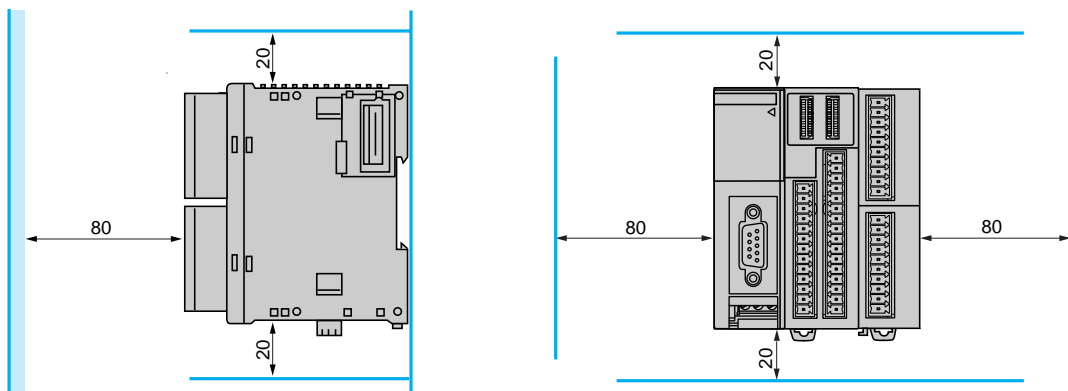

#### Important:

- Must not be horizontally or flat mounted
- Avoid placing the module over a source of heat (transformer, power supply, power contactor, etc.)

**Applications**

Discrete input modules



**Type**

8 $\equiv$ 24 V inputs (TWD DDI 8DT)	16 $\equiv$ 24 V inputs	32 $\equiv$ 24 V inputs
8 $\sim$ 120 V inputs (TWD DAI 8DT) (1)		

**Connection**

By removable screw terminal block	By HE10 type connector Allows use of the Telefast pre-wired system
-----------------------------------	---

**Inputs**

Voltage range
Input current
Input logic
Commons
Response time
<input type="checkbox"/> Energisation
<input type="checkbox"/> De-energisation

$\equiv$ 20.4...28.8 V (TWD DDI 8DT)		
$\sim$ 85...132 V (TWD DAI 8DT)		
15 mA per point	7 mA per point	5 mA per point
Sink (2)	Sink/source (2)	
1 common point (TWD DDI 8DT)	2 common points	
2 common points (TWD DAI 8DT)		
4 ms (TWD DDI 8DT), 25 ms (TWD DAI 8DT)		
4 ms (TWD DDI 8DT), 30 ms (TWD DAI 8DT)		

**Outputs**

Output types
Voltage range
Commons
Output current
<input type="checkbox"/> Per output
<input type="checkbox"/> Per group of channels

Output types, Voltage range, Commons, Output current, Per output, Per group of channels

**Isolation**

Between channels: common point,  
Between bus and channels: by photocoupler

**I/O module type**

TWD DAI 8DT    TWD DDI 16DT    TWD DDI 16DK    TWD DDI 32DK

**Pages**

16

(1) Only compatible with Advantys OTB distributed I/O  $\geq$  version 1.3 and configuration software version  $\geq$  3.0.  
(2) Sink input: positive logic, source input: negative logic.

Discrete mixed I/O modules

Master module for AS-Interface cabling system



4  $\Rightarrow$  24 V inputs/4 relay outputs

16  $\Rightarrow$  24 V inputs/8 relay outputs

By removable screw terminal block

By non-removable spring terminal block

$\Rightarrow$  20.4...28.8 V

7 mA per point

Sink/source

1 common point

4 ms

4 ms

1 N/O contact

$\sim$  240 V,  $\Rightarrow$  30V

1 common point

2 common points

2 A (Ith)

7 A (Ith)

Between input channels: common point, between output channels: common point  
Between bus and channels: by photocoupler

- For Twido controller versions  $\geq$  2.0
- Management of slave modules:
  - Discrete: maximum of 62 slaves arranged in 2 banks, A/B, of 31 addresses each
  - Analogue: maximum of 7 slaves in bank A
- The AS-Interface M3 profile supports analogue profile 7.3 (7 slaves), but does not support analogue profile S-7.4.
- Not compatible with Advantys OTB distributed I/O

TWD DMM 8DRT

TWD DMM 24DRF

TWD NOI 10M3

16

-

**Applications**

8/16 output modules with removable screw terminal block



**Type**

8  $\equiv$  24 V transistor outputs      8 relay outputs      16 relay outputs

**Connection**

By removable screw terminal block

**Inputs**

- Voltage range
- Input current
- Input logic
- Commons
- Response time
  - Energisation
  - De-energisation

**Outputs**

- Output types
- Voltage range
- Logic (1)
- Commons
- Output current
  - Per output
  - Per group of channels

Transistor		Relay with 1 N/O contact	
$\equiv$ 20.4...28.8 V		$\sim$ 240 V, $\equiv$ 30V	
Sink	Source	-	
1 common point		2 common points	
0.3 A nominal		2 A max	
3 A at 28.8 V		7 A max	8 A max

**Isolation**

Between channels: common point.  
Between bus and channels: by photocoupler.

Between channels: common point.  
Between bus and channels:  $\sim$ 1500 V for 1 minute.

**Output module type**

TWD DDO 8UT    TWD DDO 8TT    TWD DRA 8RT    TWD DRA 16RT

**Pages**

16

(1) Source output: positive logic, sink output: negative logic.

16/32 output modules with HE 10 type connectors



16 --- 24 V transistor outputs

16 --- 24 V transistor outputs

32 --- 24 V transistor outputs

32 --- 24 V transistor outputs

By HE10 type connector

By HE10 type connector  
Allows use of the Telefast pre-wired system

By HE10 type connector

By HE10 type connector  
Allows use of the Telefast pre-wired system

Transistor

--- 20.4...28.8 V

Sink

Source

Sink

Source

1 common point

2 common points

0.1 A nominal

1 A at 28.8 V

Between channels: common point.  
Between bus and channels: by photocoupler.

TWD DDO 16UK

TWD DDO 16TK

TWD DDO 32UK

TWD DDO 32TK

16

### Presentation

The range of Twido I/O modules includes input modules, output modules and mixed input/output modules. With the 15 I/O modules offered, in addition to the I/O integrated in 24 I/O compact base controllers and modular base controllers, configurations can be adapted to best suit application requirements, so optimising costs. The following discrete I/O modules are available:

- 1 ~ 120 V discrete input module, 8 channels, fitted with a removable screw terminal block.
- 4 ~ 24 V discrete input modules comprising an 8-channel module, two 16-channel modules and a 32-channel module, equipped with either removable screw terminal blocks or HE 10 type connector, depending on the model. These modules can be either "sink or source".
- 8 discrete output modules comprising two output modules with 8 and 16 relay outputs, three output modules with 8, 16 or 32-channel "sink" transistor outputs and three output modules with 8, 16 or 32-channel "source" transistor outputs, equipped with either removable screw terminal blocks or HE 10 type connector, depending on the model.
- 2 discrete mixed input and output modules, comprising one 4-channel input/4-channel relay output module with removable screw terminal block and one 16-channel input/8-channel relay output module with non-removable spring terminal block.

The narrow width of these I/O modules (17.5 mm, 23.5 mm, 29.7 mm or 39.1 mm) makes it possible to build Twido configurations of up to 264 I/O with a minimal overall size of W 255.4 mm x H 90 mm x D 81.3 mm.

All these discrete I/O modules and the analogue I/O modules are connected to the TWIDO base controller or to Advantys OTB distributed I/O by stacking them on a rail, starting from the right-hand side panel of the base controller, according to the following rules:

- For 24 I/O compact base controllers TWD LC●A 24DRF: 4 modules max.
- For 40 I/O compact base controllers TWD LCA● 40DRF: 7 modules max.
- For 20 I/O modular base controllers TWD LMDA 20D●K: 4 modules max.
- for 20 and 40 I/O base controllers TWD LMDA 20DRT/40D●K: 7 modules max.
- For interface modules Advantys OTB 1●0 DM9LP: 7 modules max.

All the discrete I/O modules are electrically isolated with the use of a photocoupler between the internal electronic circuit and the input/output channels.

### Description

Twido discrete I/O modules comprise:

- 1 An extension connector for electrical connection to the previous module (1).
- 2 One or two blocks for displaying the channels and module diagnostics.
- 3 One or two connection components of varying type, depending on the model:
  - removable screw terminal block (1 or 2) for modules whose reference ends in **T**,
  - HE 10 type connector (1 or 2) for modules whose reference ends in **K**,
  - non-removable spring terminal block for module TWD DMM 24DRF.
- 4 Latching mechanism for attachment to the previous module.

These modules are mounted on a symmetrical rail. Fixing kit TWD XMT 5 (supplied in lots of 5) allows plate or panel mounting. For modules with removable screw terminal block, the terminal blocks are supplied with the module.

(1) A connector on the right-hand side panel ensures continuity of the electrical link with the next I/O module.

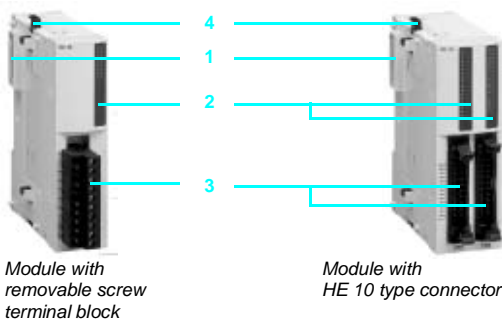











### General characteristics

Temperature	°C	Operation: 0...+ 55. Storage: - 25...+ 70.
Relative humidity		30 to 95 %, without condensation
Degree of protection		IP 20
Altitude	m	Operation: 0...2000. Storage: 0...3000.
Vibration resistance	Mounted on  rail	Hz 10...57, amplitude 0.075 mm, acceleration 57...150 Hz
		m/s <sup>2</sup> 9.8 (1 gn)
	Plate or panel mounted (using fixing kit WD XMT 5)	Hz 2...25, amplitude 1.6 mm, acceleration 25...100 Hz
	m/s <sup>2</sup> 39.2 (4 gn)	
Shock resistance	m/s <sup>2</sup>	147 (15 gn) for 11 ms





### Characteristics of input channels

Module type	TWD	DAI 8DT	DDI 8DT	DDI 16DT	DDI 16DK	DDI 32DK	DMM 8DRT	DMM 24DRF	
Number of input channels		8	8	16	16	32	4	16	
Rated input voltage	V	~ 120 V  24 sink/source							
Connection		Removable screw terminal block			HE 10 type connector		Removable screw term. block	Spring terminal block	
Commons		2	1			2	1		
Input voltage range	V	~ 85...132 V  20.4...28.8							
Rated input current	mA	7.5	7		5		7		
Input impedance	kΩ	11	3.4		4.4		3.4		
Filter time	At state 1	ms	25	8					
	At state 0	ms	30	8					
Isolation		No isolation between channels, isolation with internal logic by photocouplers							
Internal consumption for all inputs	At state 1  5 V	mA	55	25	40	35	65	25 (1)	65 (1)
	 24 V	mA	0					20 (1)	45 (1)
	At state 0  5 V	mA	25	5			10	5 (1)	10 (1)

### Characteristics of transistor output modules

Module type	TWD	DDO 8UT	DDO 8TT	DDO 16UK	DDO 16TK	DDO 32UK	DDO 32TK
Number of output channels		8		16		32	
Output logic (2)		Sink	Source	Sink	Source	Sink	Source
Connection		Removable screw terminal block		HE 10 type connector			
Commons		1				2	
Nominal output values	Voltage	V	24				
	Current	A	0.3		0.1		
Output voltage range	Voltage	V	20.4...28.8				
	Current per channel	A	0.36		0.12		
	Current per common	A	3		1		
Response time	At state 1	μs	300				
	At state 0	μs	300				
Residual voltage (voltage at state 1)	V	1 max					
Maximum inrush current	A	1					
Leakage current	mA	0.1					
Overvoltage protection	V	39					
Maximum power of filament lamp	W	8					
Isolation		No isolation between channels, isolation with internal logic by photocouplers					
Consumption for all the outputs	At state 1  5 V	mA	10		10		20
	 24 V	mA	20		40		70
	At state 0  5 V	mA	5		5		10

### Characteristics of relay output channels

Module type	TWD	DRA 8RT	DRA 16RT	DMM 8DRT	DMM 24DRF
Number of output channels		8 N/O contacts	16 N/O contacts	4 N/O contacts	8 N/O contacts
Output currents	Current per channel	A	2		
	Current per common	A	7	8	7
Minimum switching load	mA	0.1/0.1  V (reference value)			
Contact resistance (when new)	mΩ	30 max			
Loads (resistive, inductive)	A	2A/~ 240 V or 2A/  30 V (with 1800 operations/hour max): - electrical life: minimum 100 000 operations. - mechanical life: minimum 20 x 10 <sup>6</sup> operations.			
rms insulation voltage	V	~ 1 500 for 1 minute			
Consumption for all the outputs	At state 1  5 V	mA	30	45	See values above (input channels)
	 24 V	mA	40	75	See values above (input channels)
	At state 0  5 V	mA	5	5	See values above (input channels)

(1) Consumption values are indicated for all inputs/outputs at state 0 or at state 1.

(2) Source output: positive logic, sink output: negative logic.

# IP 20 distributed inputs/outputs

## Discrete I/O modules

### References

These discrete I/O modules are mounted as standard on symmetrical  $\sim$  rails to the right of the Twido base controller. The maximum number of discrete and/or analogue I/O modules which may be mounted depends on the type of base controller:

Type of TWD base	LC●A 10DRF	LC●A 16DRF	LC●A 24DRF	LCA● 40DRF	LMDA 20D●K	LMDA 20DRT	LMDA 40D●K
Number of modules	0	0	4	7	4	7	7

### Discrete input modules

Input voltage	No. of channels	No. of common points	Connection	Reference	Weight kg
$\equiv$ 24 V sink/source	8	1	Removable screw terminal block (supplied)	TWD DDI 8DT	0.085
	16	1	Removable screw terminal block (supplied)	TWD DDI 16DT	0.100
			HE10 type connector	TWD DDI 16DK (1)	0.065
	32	2	HE10 type connector	TWD DDI 32DK (1)	0.100
$\sim$ 120 V	8	2	Removable screw terminal block (supplied)	TWD DAI 8DT	0.081

### Discrete output modules

Type of output	No. of channels	No. of common points	Connection	Reference	Weight kg
Transistor $\equiv$ 24 V/0.3 A	8, sink	1	Removable screw terminal block (supplied)	TWD DDO 8UT	0.085
	8, source	1	Removable screw terminal block (supplied)	TWD DDO 8TT	0.085
Transistor $\equiv$ 24 V/0.1 A	16, sink	1	HE10 type connector	TWD DDO 16UK	0.070
	16, source	1	HE10 type connector	TWD DDO 16TK (1)	0.070
	32, sink	2	HE10 type connector	TWD DDO 32UK	0.105
	32, source	2	HE10 type connector	TWD DDO 32TK (1)	0.105
Relay 2 A (lth) $\sim$ 230 V/ $\equiv$ 30 V	8 (N/O contact)	2	Removable screw terminal block (supplied)	TWD DRA 8RT	0.110
	16 (N/O contact)	2	Removable screw terminal block (supplied)	TWD DRA 16RT	0.145

### Discrete mixed input/output modules

No. of I/O	No. and type of inputs	No. and type of outputs	No. of common points	Connection	Reference	Weight kg
8	4 I, $\equiv$ 24 V sink/source	4 O, relay (N/O contact) 2 A (lth)	Inputs: 1 common Outputs: 1 common	Removable screw terminal block (supplied)	TWD DMM 8DRT	0.095
24	16 I, $\equiv$ 24 V sink/source	8 O, relay (N/O contact) 2 A (lth)	Inputs: 1 common Outputs: 2 commons	Non-removable spring terminal block	TWD DMM 24DRF	0.140

(1) Module allowing use of the Telefast pre-wired system.



TWD DDI 8DT



TWD DDI 32DK



TWD DDO 8●T/DRA 8RT



TWD DDO 16●K



TWD DDO 32●K



TWD DRA 16RT



TWD DDM 8DRT



TWD DDM 24DRF

# IP 20 distributed inputs/outputs

## Discrete I/O modules

### References

#### Separate components

Application	Description	Reference	Weight kg
Fixing kit	For plate or panel mounting of the discrete modules. Sold in lots of 5	TWD XMT 5	–
Telefast pre-wired system for Twido	Connection sub-bases I/O connection sub-bases Pre-wired solutions Cables and accessories	See page 41	–

#### HE 10 type connectors

Description	Number of ways	Reference	Weight kg
HE 10 female connectors (sold in lots of 5)	20	TWD FCN 5K20	–
	26	TWD FCN 5K26	–

#### Pre-formed cables for discrete I/O modules with HE 10 connectors

Description	For use with Twido	Gauge c.s.a.	Cable length	Reference	Weight kg
Pre-formed cables, 1 pre-formed cable: one end with HE 10 connector, one end with free wires	Modular base controllers	22	3 m	TWD FCW 30M	0.405
	TWD LMDA	22	5 m	TWD FCW 50M	0.670
	20DTK/40DTK	0.035 mm <sup>2</sup>			
	I/O extensions	22	3 m	TWD FCW 30K	0.405
	TWD DDI	0.035 mm <sup>2</sup>			
	16DK/32DK TWD DDO 16●K/32●K	22 0.035 mm <sup>2</sup>	5 m	TWD FCW 50K	0.670

#### Connecting cables (1)

Description	For use with Twido	Gauge c.s.a.	Cable length	Reference	Weight kg
Discrete I/O pre-formed cables, 1 pre-formed cable: one end with 26-way HE 10 connector on Twido side, one end with two 20-way HE 10 connectors on Telefast side	Modular base controllers	28	1 m	ABF TP26MP100	0.200
	TWD LMDA	0.080 mm <sup>2</sup>			
	20DTK/40DTK	28	2 m	ABF TP26MP200	0.500
		0.080 mm <sup>2</sup>			
Discrete input pre-formed cables, 1 pre-formed cable: one end with 20-way HE 10 connector on Twido side, one end with 20-way HE 10 connector on Telefast side	Inputs	28	1 m	ABF TE20EP100	0.080
	TWD DDI	0.080 mm <sup>2</sup>			
	16DK/32DK	28	2 m	ABF TE20EP200	0.140
Discrete output pre-formed cables 1 pre-formed cable: one end with 20-way HE 10 connector on Twido side, one end with 20-way HE 10 connector on Telefast side	Outputs	28	1 m	ABF TE20SP100	0.080
	TWD DDO	0.080 mm <sup>2</sup>			
	16TK/32TK	28	2 m	ABF TE20SP200	0.140
	0.080 mm <sup>2</sup>				
		28	3 m	ABF TE20SP300	0.210
		0.080 mm <sup>2</sup>			

(1) Cables strictly for applications other than use of Telefast sub-bases with Twido controllers.  
For use of Telefast sub-bases with Twido controllers, see pages 32 to 45.

### Dimensions

#### Discrete I/O modules

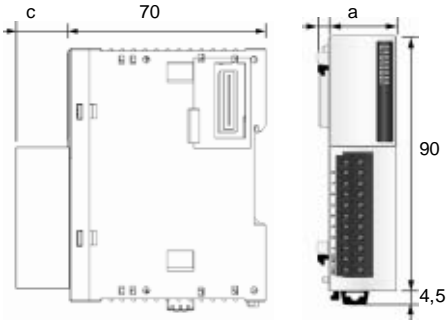

TWD	a	c
DDI 8DT/DAI 8DT	23.5	14.6
DDI 16DT	23.5	14.6
DDI 16DK	17.6	11.3
DDI 32DK	29.7	11.3
DDO 8UT/8TT	23.5	16.6
DDO 16UK/16TK	17.6	11.3
DDO 32UK/32TK	29.7	11.3
DRA 8RT/16RT	23.5	14.6
DMM 8DRT	23.5	14.6
DMM 24DRF	39.1	1.0

### Connections

#### ABF TP26MP●00

HE 10 26-way A	HE 10 20-way B	HE 10 20-way C
Twido side	Input side	Output side
1	–	18
2	20	–
3	–	20
4	12	–
5	–	17
6	11	–
7	–	19
8	10	–
9	–	–
10	9	–
11	–	8
12	8	–
13	–	7
14	7	–
15	–	6
16	6	–
17	–	5
18	5	–
19	–	4
20	4	–
21	–	3
22	3	–
23	–	2
24	2	–
25	–	1
26	1	–

#### ABF TE20EP●00

HE 10 20-way A	HE 10 20-way B
Twido side	Input side
1	–
2	–
3	18
4	20
5	16
6	8
7	15
8	7
9	14
10	6
11	13
12	5
13	12
14	4
15	11
16	3
17	10
18	2
19	9
20	1

#### ABF TE20SP●00

HE 10 20-way A	HE 10 20-way B
Twido side	Output side
1	18
2	20
3	19
4	17
5	16
6	8
7	15
8	7
9	14
10	6
11	13
12	5
13	12
14	4
15	11
16	3
17	10
18	2
19	9
20	1

### Connections

#### Input modules

**TWD DDI 8DT** ( $\approx 24$  V)

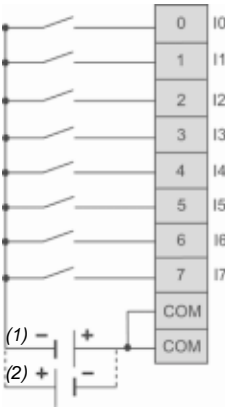

**TWD DAI 8DT** ( $\sim 120$  V)

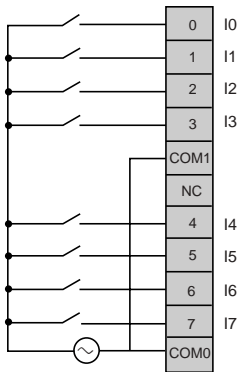

**TWD DDI 16DK** ( $\approx 24$  V)

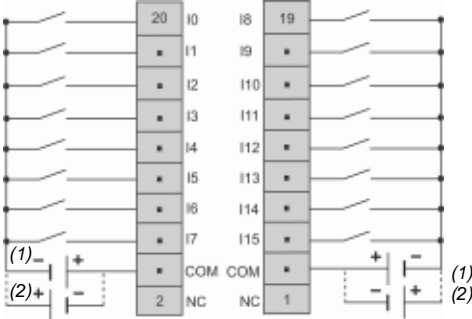

□ The COM terminals are linked internally.

**TWD DDI 16DT** ( $\approx 24$  V)

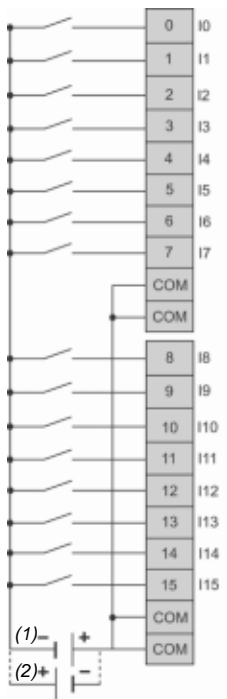

□ The COM terminals are linked internally.

□ The COM terminals are linked internally.

**TWD DDI 32DK** ( $\approx 24$  V)

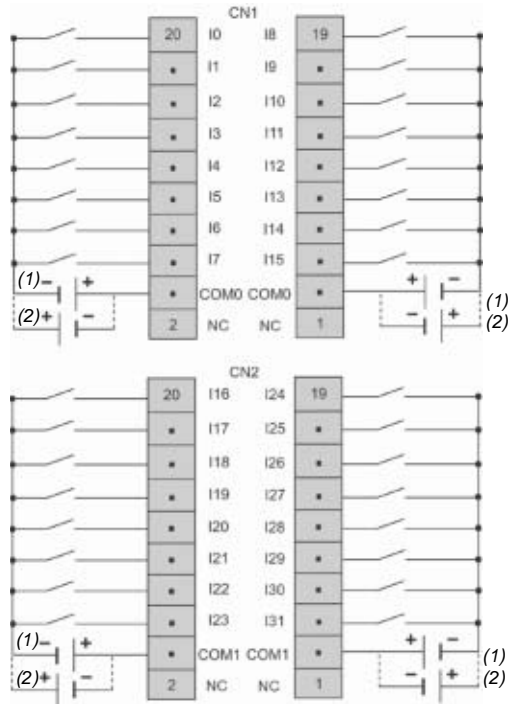

□ The COM0 terminals are linked internally.  
□ The COM1 terminals are linked internally.

(1) Source input (negative logic).

(2) Sink input (positive logic).

**Transistor output modules**

**TWD DDO 8UT**

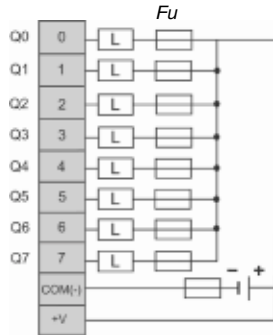

**TWD DDO 8TT**

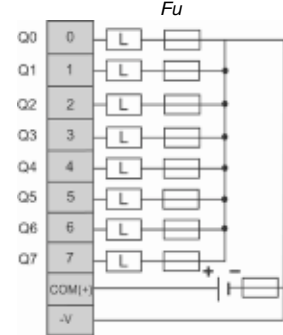

**TWD DDO 16UK**

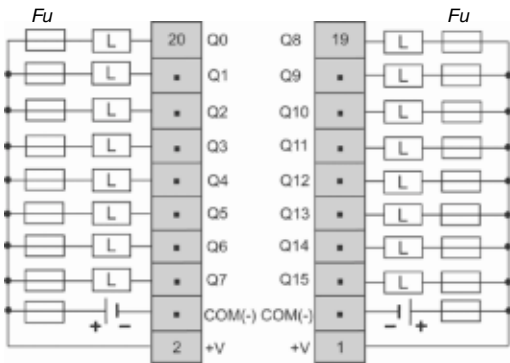

**TWD DDO 16TK**

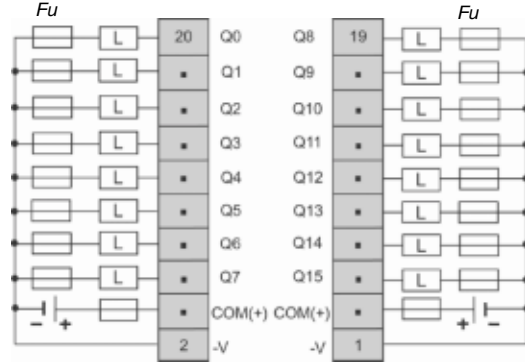

**TWD DDO 32UK**

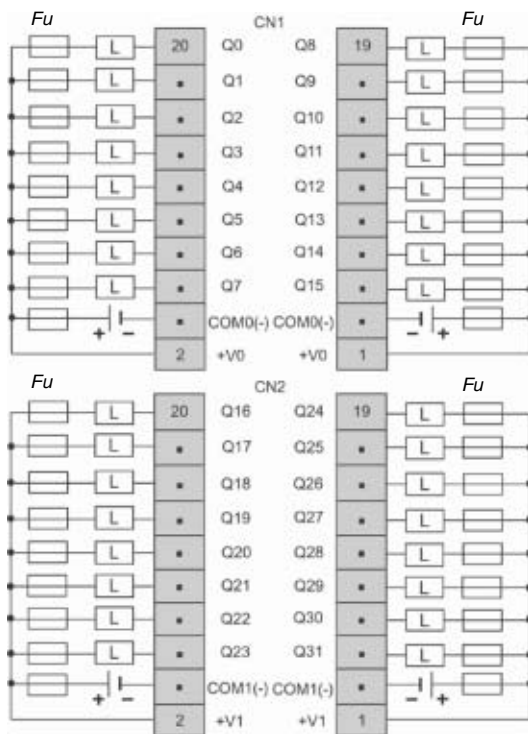

**TWD DDO 32TK**

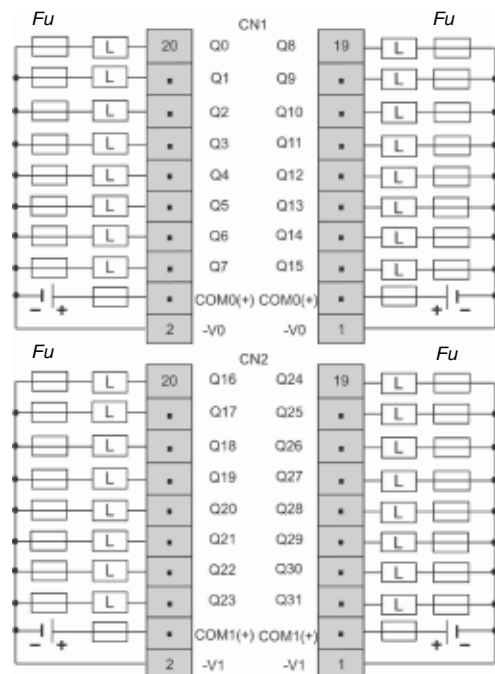

**Terminals:**

- COM (-) are linked internally.
- COM0 (-) are linked internally.
- COM1 (-) are linked internally.
- + V are linked internally.
- + V0 are linked internally.
- + V1 are linked internally.

**Terminals:**

- COM (+) are linked internally.
- COM0 (+) are linked internally.
- COM1 (+) are linked internally.
- V are linked internally.
- V0 are linked internally.
- V1 are linked internally.

### Relay output modules

TWD DRA 8RT

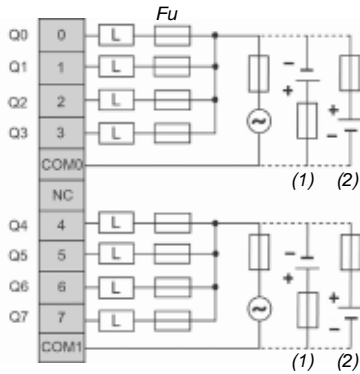

TWD DRA 16RT

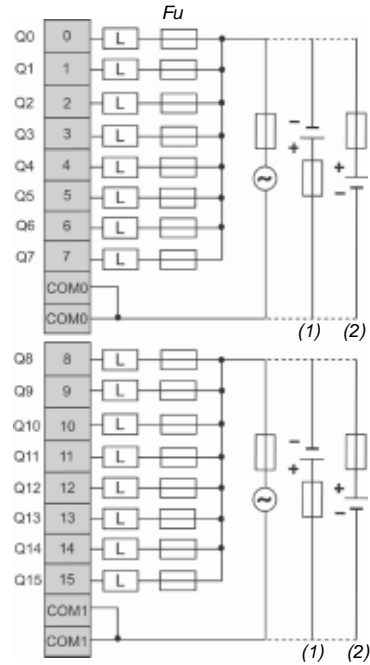

Terminals:

- COM0 are linked internally.
- COM1 are linked internally.
- COM0 and COM1 are independent

- (1) Sink output (negative logic)  
 (2) Source output (positive logic)

### Mixed input/output modules

TWD DMM 8DRT

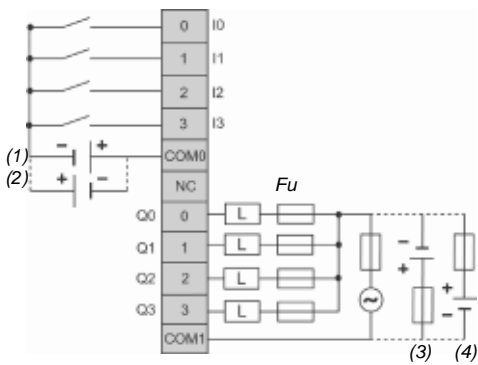

TWD DMM 24DRT

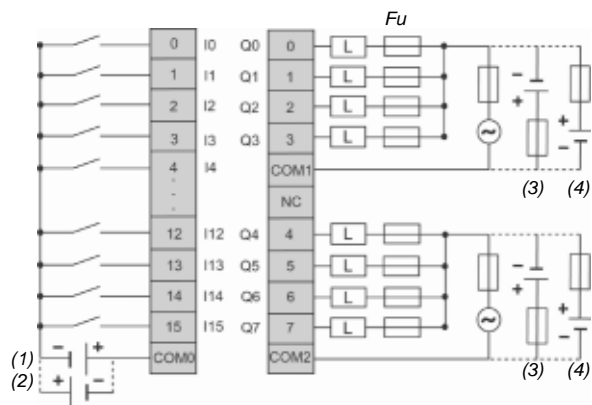

- The COM (+) terminals are linked internally

- Terminals COM0, COM1 and COM2 are independent
- The - V terminals are linked internally.

- (1) Source input (negative logic)  
 (2) Sink input (positive logic)  
 (3) Sink output (negative logic)  
 (4) Source output (positive logic)

<b>Applications</b>		Analogue input modules			
					
<b>Number of I/O</b>		2 inputs	4 inputs	8 inputs	8 inputs
<b>Type</b>		Voltage/current	Voltage/current Temperature	Voltage/current	PTC/NTC
<b>Connection</b>		Removable screw terminal block			
<b>Inputs</b>	Range	0...10 V (non differential) 4...20 mA (differential)	0...10 V (non differential) 0...20 mA (differential) Pt 100/1000 NI 100/1000	0...10 V (non differential) 0...20 mA (differential)	–
	Resolution	10 bits (1024 points)	12 bits (4096 points)	10 bits (1024 points)	
	Acquisition period	32 ms + 1 controller cycle time	160 ms		
<b>Outputs</b>	Range				
	Resolution				
	Transfer time				
<b>External supply</b>		≡ 24 V external power supply to sensors/preactuators (voltage range 20.4...28.8 V)			
<b>Isolation</b>		Isolation between channels and earth: by photocoupler			
<b>Analogue I/O module type</b>		TWD AMI 2HT	TWD AMI 4LT (1)	TWD AMI 8HT (1)	TWD ARI 8HT (1)
<b>Pages</b>		27			

(1) Only compatible with Advantys OTB distributed I/O ≥ version 1.3 and configuration software version ≥ 3.0.



Analogue output modules

Analogue mixed I/O modules

Master module for AS-Interface cabling system



1 output

2 outputs

2 inputs/1 output

Voltage/current

Voltage

Voltage/current

Thermocouple/temperature probe inputs  
Voltage/current output

Removable screw terminal block

0...10 V (non differential)  
4...20 mA (differential)

Thermocouple type K, J and T  
Pt 100 3-wire temperature probe

12 bits (4096 points)

32 ms + 1 controller cycle time

100 ms + 1 controller cycle time

0...10 V  
4...20 mA

± 10 V

0...10 V  
4...20 mA

12 bits (4096 points)

11 bits + sign (2048 points)

12 bits (4096 points)

20 ms + 1 controller cycle time

0.3 ms + 1 controller cycle time

20 ms + 1 controller cycle time

- For Twido controller versions  $\geq 2.0$
- Management of slave modules:
  - Discrete: maximum of 62 slaves arranged in 2 banks, A/ B, of 31 addresses each
  - Analogue: maximum of 7 slaves in bank A
- The AS-Interface M3 profile supports analogue profile 7.3 (7 slaves), but does not support analogue profile S-7.4.
- Not compatible with Advantys OTB distributed I/O

TWD AMO 1HT

TWD AVO 2HT  
(1)

TWD AMM 3HT

TWD ALM 3LT

TWD NOI 10M3

27

–

(1) Only compatible with Advantys OTB distributed I/O  $\geq$  version 1.3 and configuration software version  $\geq$  3.0.

### Presentation

Twido analogue I/O expansion modules enable the acquisition of various analogue values encountered in industrial applications.

Analogue output modules are used to control the preactuators in devices such as variable speed drives, valves and applications that require process control. The output current or voltage is proportional to the numerical value defined by the user program. When the Twido controller stops, the outputs can be configured with fallback (reset to the lowest scale value or hold the last value received). This function, when set to 'hold', is useful when debugging the application or when a fault occurs, in order not to disturb the process being controlled.

The 8 following analogue I/O modules are available:

- One module with 2 inputs: 0...10 V, 4...20 mA.
- One module with 4 inputs: 0...10 V, 0...20 mA, Pt 100/1000, Ni100/1000 range 50...150 °C.
- One module with 8 inputs: 0...10 V, 0...20 mA.
- One module with 8 inputs: PTC/NTC.
- One module with 1 output: 0...10 V, 4...20 mA.
- One module with 2 outputs: ± 10 V.
- One mixed module with 2 inputs: 0...10 V, 4...20mA and 1 output: 0...10 V, 4...20mA.
- One mixed module with 2 thermocouple or temperature probe inputs and one 0...10 V, 4...20 mA output.

Twido analogue extension modules offer a resolution of 10 bits, 11 bits + sign and 12 bits, with connection by removable screw terminal block. An external 24 V power supply is required for each analogue module.

Like discrete I/O modules, analogue I/O modules are connected to the base controller by stacking them on a rail, starting from the right-hand side panel of the base controller, according to the following rules:

- For 24 I/O compact base controllers TWD LC●A 24DRF: 4 modules max.
- For 40 I/O compact base controllers TWD LCA● 40DRF: 7 modules max.
- For 20 I/O modular base controllers TWD LMDA 20D●K: 4 modules max.
- For 40 I/O modular base controllers TWD LMDA 20DRT/40D●K: 7 modules max.
- For interface modules Advantys OTB 1● DM9LP: 7 modules max. or 24 input channels and 24 output channels max.

All analogue I/O modules are electrically isolated with the use of a photocoupler between the internal electronic circuit and the input/output channels.

### Description

Twido analogue I/O modules comprise:

- 1 An extension connector for electrical connection to the previous module (1).
- 2 A block for displaying the channel and module diagnostics.
- 3 A removable screw terminal block for connection of the 24 V external power supply, the sensors and the preactuators.
- 4 A latching mechanism for attachment to the previous module.

These modules are mounted on a symmetrical rail. Fixing kit TWD XMT 5 (supplied in lots of 5) allows plate or panel mounting.

(1) A connector on the right-hand side panel ensures continuity of the electrical link with the next I/O module.

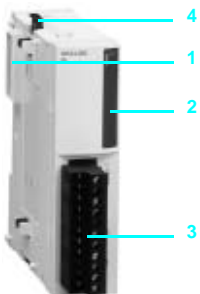

General characteristics		
Temperature	°C	Operation: 0...+ 55. Storage: - 25...+ 70.
Relative humidity		30 to 95 %, without condensation
Degree of protection		IP 20
Altitude	m	Operation: 0...2000. Storage: 0...3000.
Vibration resistance	Rail mounted	Hz 10...57, amplitude 0.075 mm, acceleration 57...150 Hz m/s <sup>2</sup> 9.8 (1 gn)
	Plate or panel mounted (using fixing kit TWD XMT 5)	Hz 2...25, amplitude 1.6 mm, acceleration 25...100 Hz m/s <sup>2</sup> 39.2 (4 gn)
Shock resistance	m/s <sup>2</sup>	147 (15 gn) for 11 ms

Analogue input characteristics						
Module type		TWD AMI 2HT/AMM 3HT		TWD ALM 3LT		
Number of channels		2 high-level inputs		2 low-level inputs		
Range		Voltage	Current	Thermocouple	Temperature probe	
		0...10 V	4...20 mA	Type K (0...1300° C) Type J (0...1200° C) Type T (0...400° C)	Pt probe, 3-wire type (- 100...500° C)	
Type		Non differential	Differential			
Resolution		4096 points (12 bits)				
LSB value		2.5 mV	4 µA	0.325° C (type K) 0.3° C (type J) 0.1° C (type T)	0.15° C	
Connection		Removable screw terminal block				
Permissible continuous overload		--- 13 V	40 mA	-		
External supply	V	Rated voltage: --- 24. Voltage range: --- 20.4...28.8				
Input impedance		1 MΩ min	10 Ω	250 Ω max	5 Ω max	
Maximum sampling duration	ms	16		50		
Sampling repetition time	ms	16		50		
Acquisition period	ms	32 + 1 controller cycle time		100 + 1 controller cycle time		
Measuring precision	Maximum error at 25° C	% PE	± 0.2		0.2 + precision of cold junction compensation (± 4° C max)	± 0.2
	Temperature coefficient	% PE/°C	± 0.006			
	Repeat accuracy after stabilisation time	% PE	± 0.5			
	Non linearity	% PE	± 0.2			
	Total error	% PE	± 1			
Common mode rejection		- 50 dB				
Cross talk		2 low significance bits max.				
Cabling		Twisted shielded pair recommended		-		
Dielectric strength	V rms	~ 500 between the input and the supply circuit				
Type of protection		Photocoupler between the input and the internal circuit				
Consumption	Internal supply --- 5 V	mA	50			
	External supply --- 24 V	mA	60			

Analogue input characteristics (continued)								
Module type		TWD AMI 4LT			TWD ARI 8HT		TWD AMI 8HT	
Number of channels		4 inputs			8 inputs		8 inputs	
Range		Temperature	Current	Voltage	Temperature	Current	Voltage	
		PT100, PT1000, Ni100, Ni1000	0...20 mA	0...10 V	NTC, PTC, 100 Ω<R<10 kΩ	0...20 mA	0...10 V	
Type		Differential	Non differential		Differential	Non differential		
Resolution		12 bits			10 bits			
LSB value		–	9 mV	20 μA	–	2,5 mA	4 μA	
Connection		Removable screw terminal block						
Permissible continuous overload		–	13 V	40 mA	–	40 mA	13 V	
External supply		V Rated voltage: --- 24. Voltage range: --- 20.4...28.8						
Input impedance		>1 MΩ	470 Ω	1 MΩ	>1 MΩ	470 Ω	1 MΩ	
Maximum sampling duration		ms 160						
Sampling repetition time		ms 4			8			
Acquisition period		ms 640 + 1 controller cycle time			1280 + 1 controller cycle time			
Measuring precision		Maximum error at 25° C		% PE 0.5		1		
Consumption		Internal supply --- 5 V		mA 50		50		
		External supply --- 24 V		mA 60		50		
Applicable load		–						
Dielectric strength		2500 V between the inputs and the internal circuit						

Analogue output characteristics						
Module type		TWD AMO 1HT/AMM 3HT/ALM 3LT			TWD AVO 2HT	
Number of channels		1 output			2 outputs	
Range		Voltage	Current		Voltage	
		0...10 V	4...20 mA		±10 V	
Resolution		4096 increments (12 bits)			11 bits + sign	
LSB value		2.5 mV	4 μA		± 4.8 mV	
Load impedance		Ω	2000 min	300 max	3000 min	
Applicable load		Resistive				
Stabilisation time		ms 20		0,3		
Total output system transfer time		ms 20 + 1 controller cycle time		0.3 + 1 controller cycle time		
External supply		V Rated voltage: --- 24. Voltage range: --- 20.4...28.8				
Measuring precision		Maximum error at 25° C		% PE ± 0.2		
		Temperature coefficient		% PE/°C ± 0.015		
		Repeat accuracy after stabilisation time		% PE ± 0.5		
		Output error		% PE ± 1		
		Non linearity		% PE ± 0.2		
		Output ripple		1 low significance bit max.		
		Total error		% PE ± 1		
Cabling		Twisted shielded pair recommended				
Dielectric strength		V rms ~ 500 between the input and the supply circuit				
Consumption		Internal supply --- 5 V		mA 50		
(for TWD AMO 1HT)		External supply --- 24 V		mA 40		
Applicable load		–				
Dielectric strength		–				
		2500 V between the outputs and the internal circuit				

### References

These analogue I/O expansion modules are mounted on symmetrical  $\overline{L}$  rails to the right of the Twido base controller. The sensors/preactuators are connected to a removable screw terminal block (supplied with each module). The maximum number of I/O and/or analogue modules which may be mounted depends on the type of base controller:

Type of TWD controller	LC●A 10DRF	LC●A 16DRF	LC●A 24DRF	LCA● 40DRF	LMDA 20D●K	LMDA 20DRT	LMDA 40D●K
Number of modules	0	0	4	7	4	7	7



TWD AMI 2HT



TWD ALM 3LT

#### Analogue input modules

Channel type	Input range	Output range	Resolution	Reference	Weight kg
2 inputs	0...10 V 4...20 mA	–	12 bits	TWD AMI 2HT	0.085
4 inputs	0...10 V 0...20 mA Temperature	–	12 bits	TWD AMI 4LT	0.085
8 inputs	0...10 V 0...20 mA	–	10 bits	TWD AMI 8HT	0.085
8 inputs	PTC/NTC	–	10 bits	TWD ARI 8HT	0.085

#### Analogue output modules

1 output	–	0...10 V 4...20 mA	12 bits	TWD AMO 1HT	0.085
2 outputs	–	± 10 V	11 bits + sign	TWD AVO 2HT	0.085

#### Analogue I/O modules

2 inputs and 1 output	0...10 V 4...20 mA	0...10 V 4...20 mA	12 bits	TWD AMM 3HT	0.085
	Thermocouple K, J, T Temperature probe Pt 100	0...10 V 4...20 mA	12 bits	TWD ALM 3LT	0.085

#### Separate components

Application	Description	Reference	Weight kg
Fixing kit	For plate or panel mounting of the analogue modules. Sold in lots of 5	TWD XMT 5	–
Telefast pre-wired system for Twido	Connection sub-bases I/O connection sub-bases Pre-wired solutions Cables and accessories	See page 40	–

### Dimensions

#### Analogue I/O modules

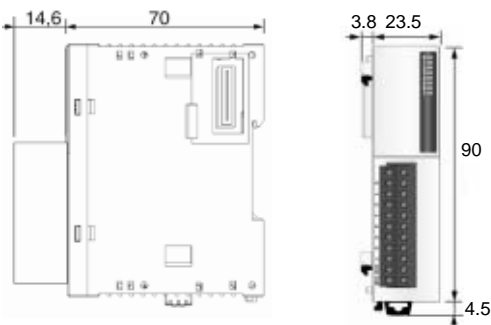

### Analogue input modules

#### TWD AMI 2HT

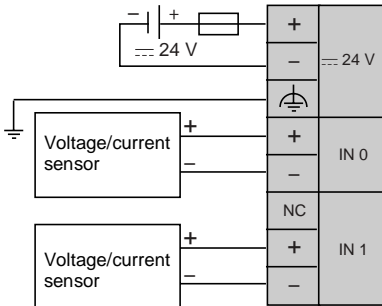

- Fit a fuse of appropriate size for the sensor type.
- Do not connect any wires to the unused channel.

#### TWD AMI 4LT

Voltage/Current configuration

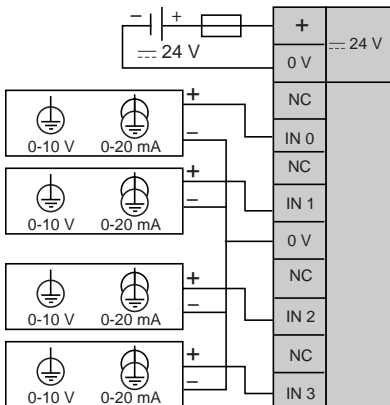

PT100/PT1000 temperature probe, Ni100/Ni1000 configuration

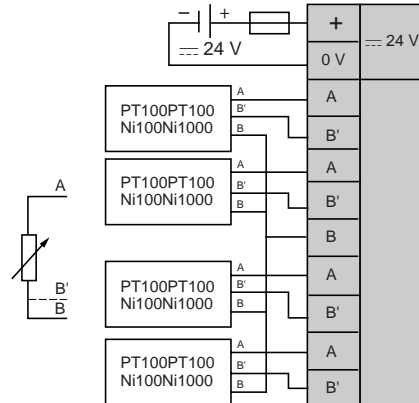

#### TWD AMI 8HT

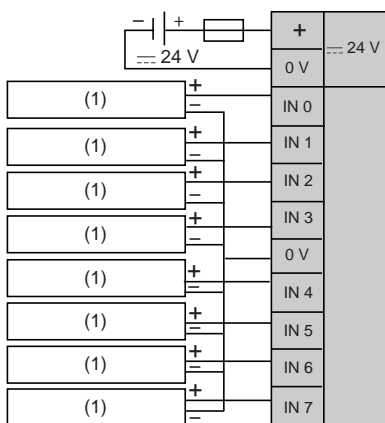

#### TWD ARI 8HT

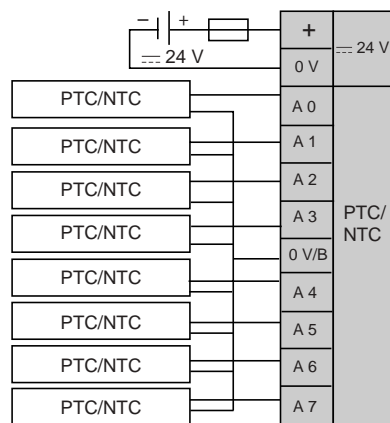

(1) Analogue current/voltage output peripheral.

- Fit a fuse of appropriate size for the sensor type.
- Do not connect any wires to the unused channel.

### Analogue output modules

#### TWD AMO 1HT

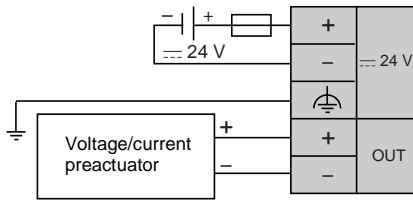

#### TWD AVO 2HT

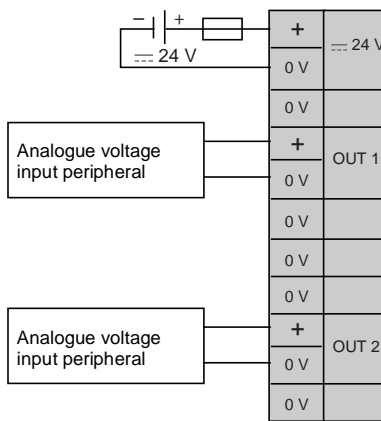

- Fit a fuse of appropriate size for the sensor type.
- Do not connect any wires to the unused channel.

### Mixed input/output module

#### TWD AMM 3HT

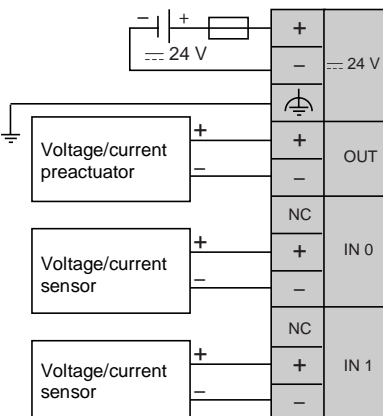

#### TWD ALM 3LT

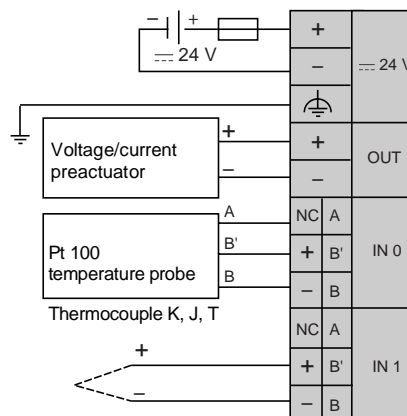

- Fit a fuse of appropriate size for the sensor and preactuator types.
- For a Pt 100 3-wire temperature probe (RTD), connect the three wires to terminals A, B' and B (channels IN0 and IN1).
- For a Pt 100 2-wire temperature probe (RTD), connect the two wires to terminals A and B' and make a bridge between B' and B (channels IN0 and IN1).
- For a thermocouple, connect the two wires to the + and - terminals (channels IN0 and/or IN1).
- Do not connect any wires to unused channels.

# IP 20 distributed inputs/outputs

Advantys, Telefast® pre-wired system for I/O modules  
Connection sub-bases

Applications

Connection sub-bases for discrete inputs and outputs



Compatibility

Twido modular base controllers equipped with HE 10 connectors  
Not compatible with Advantys OTB distributed I/O

Relay amplification

–

Electromechanical and solid state, fixed

Control voltage

~ 24 V

Output voltage

~ 24 V

~ 24 V (solid state)  
~ 5...30 V,  
~ 250 V (electromechanical)

Current per channel

Input	5...7 mA	5...7 mA
Output	0.3 A	2 A (solid state) 3 A (electromechanical)

5...7 mA  
0.3 A

5...7 mA  
2 A (solid state)  
3 A (electromechanical)

Modularity

20 (12 inputs/8 outputs)

Type of I/O

- 12 inputs (1 common/12 channels)
- 8 outputs (1 common/8 channels)

- 12 inputs (1 common/12 channels)
- 8 outputs with fuse protection (1 common/8 channels)

LED indication

- 12 inputs (1 common/12 channels)
- 2 solid state outputs (1 common/2 channels)
- 6 relay outputs (electromechanical) 1 N/O (1 common/6 channels)

Number of terminals per channel

2  
3 (with optional snap-on terminal block)

Connection to Twido programmable controller

HE 10 connector, 26-way

Type of terminal

Fixed screw terminal block

Interface type

**ABE 7B20MPN20**

**ABE 7B20MPN22**

**ABE 7B20MRM20**

Pages

40

40

40



**Connection sub-bases for discrete inputs**

**Connection sub-bases for discrete outputs**



Twido I/O modules with HE 10 connectors  
Advantys OTB distributed I/O

-	Electromechanical, fixed
---	--------------------------

~ 24 V	
--------	--

~ 24 V	~ 5...30 V, ~ 250 V (electromechanical)
--------	--

5 mA	-	-
-	0.1 A	3 A

16 inputs	16 outputs
-----------	------------

<input type="checkbox"/> 16 inputs (1 common/16 channels)	<input type="checkbox"/> 16 outputs (1 common/16 channels)	<input type="checkbox"/> 16 outputs with fuse protection LED indication	<input type="checkbox"/> 16 relay outputs (electromechanical) 1 N/O (1 common/4 channels)
--	---	--	---

2  
3 (with optional snap-on terminal block)

HE 10 connector, 20-way

Fixed screw terminal block

<b>ABE 7E16EPN20</b>	<b>ABE 7E16SPN20</b>	<b>ABE 7E16SPN22</b>	<b>ABE 7E16SRM20</b>
----------------------	----------------------	----------------------	----------------------

40	40	40	40
----	----	----	----

# IP 20 distributed inputs/outputs

## Advantys, Telefast® pre-wired system for I/O modules

### Connection sub-bases

#### Presentation

Relay and connection functions, with or without polarity distribution, significantly reduce wiring time and eliminate the risk of error.

The AdvantysTelefast pre-wired system allows fast, reliable and economical remote connection of I/O modules (≐ 24 V discrete) to operative parts, partly eliminating the single-wire connection and intermediate terminal blocks.

The Telefast system can only be connected to Twido modules equipped with HE 10 type connectors. It consists of connecting cables and interface sub-bases.

The Telefast range is suitable for all types of connection found in control system devices:

- I/O located in the PLC cabinet,
- I/O located directly on the machine or in auxiliary enclosures.

All the I/O connection sub-bases comprise output terminals on 2 rows :

- 1<sup>st</sup> row: connection of the signal,
- 2<sup>nd</sup> row: connection of its common
- ≐ 24 V for the inputs,
- 0 V for the outputs.

A 3<sup>rd</sup> row of optional terminals ABE 7BV●● may be added for connection of another common.

These I/O sub-bases are available in different configurations:

#### Sub-bases for Twido modular base controllers

- **ABE 7B20MPN20**: sub-base with 12 inputs + 8 passive outputs.
- **ABE 7B20MPN22**: sub-base with 12 inputs + 8 passive outputs.
  - individual fuse protection for each output (0.315 A),
  - LED indication,
  - blade disconnecter for the 0 V common.
- **ABE 7B20MRM20**: sub-base with 12 inputs + 8 outputs with soldered relays
  - 2 A solid state relay (1 x 4 A common/2 channels) on 2 outputs,
  - electromechanical relays (1N/O ≐ 24 V/~ 250 V, 3 A) on 6 outputs for adaptation of the current or voltage signal (1 x 10 A common/6 channels).

#### Sub-bases for Twido extension modules

- **ABE 7E16EPN20**: sub-base with 16 passive inputs.
- **ABE 7E16SPN20**: sub-base with 16 passive outputs.
- **ABE 7E16SPN22**: sub-base with 16 passive outputs.
  - individual fuse protection for each output (0.315 A),
  - LED indication
  - blade disconnecter for breaking the 0 V common.
- **ABE 7E16SRM20**: sub-base with 16 soldered relay outputs
  - electromechanical relays (1N/O ≐ 24 V/~ 250 V, 3 A) on 16 outputs for adapting the current or voltage signal (1 x 5 A common/4 channels)

#### Optional terminal blocks

- **ABE 7BV20TB**
  - 12 shunted screw terminals for the input common,
  - 8 shunted screw terminals for the output common.
- **ABE 7BV20**
  - 20 shunted screw terminals for connection of a single common.

# IP 20 distributed inputs/outputs

Advantys, Telefast® pre-wired system for I/O modules  
Connection sub-bases

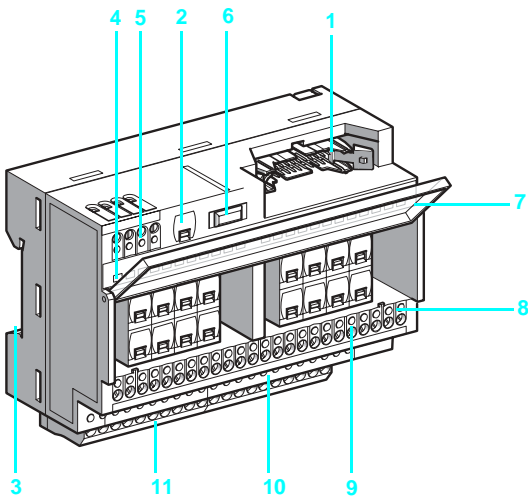

## Description

Connection sub-bases ABE 7B20M●●●●, ABE 7E16SRM20 and ABE 7E16SPN22

- 1 HE 10 connector (20-way for ABE 7E16●●●●●, 26-way for ABE 7B20●●●●●).
- 2 Fuse for the  $\text{---}$  24 V supply circuit.
- 3 Rail mounting.
- 4 LED for channel indication (only on ABE 7B20MPN22 and ABE 7E16SPN22).
- 5  $\text{---}$  24 V power supply terminal block.
- 6 Blade disconnector on  $\text{---}$  0 V (only on ABE 7B20MPN22 and ABE 7E16SPN22).
- 7 Legend holder cover: customer marking on outside and sub-base wiring scheme on inside, providing access to fuses per channel (only on ABE 7B20MPN22 and ABE 7E16SPN22).
- 8 Test point for  $\text{Ø}$  2.3 mm plug.
- 9 Upper terminal block for connection of signals.
- 10 Lower terminal block for connection of commons.
- 11 Optional snap-on terminal block with 20 screw terminals.

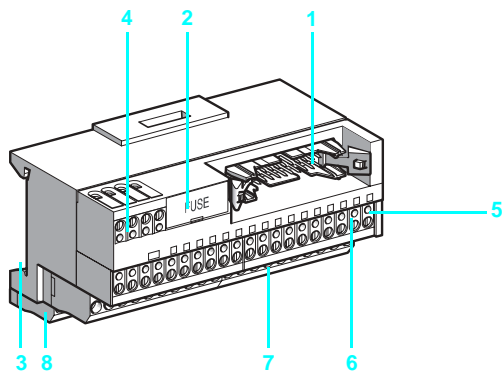

## Connection sub-bases ABE 7E16EPN20 and ABE 7E16SPN20

- 1 HE 10 connector, 20-way,
- 2 Fuse for the  $\text{---}$  24 V supply circuit.
- 3 Rail mounting.
- 4  $\text{---}$  24 V power supply terminal block.
- 5 Test point for  $\text{Ø}$  2.3 mm plug.
- 6 Upper terminal block for connection of signals.
- 7 Lower terminal block for connection of commons.
- 8 Optional snap-on terminal block with 20 screw terminals.

# IP 20 distributed inputs/outputs

Advantys, Telefast® pre-wired system for I/O modules

Pre-wired solutions

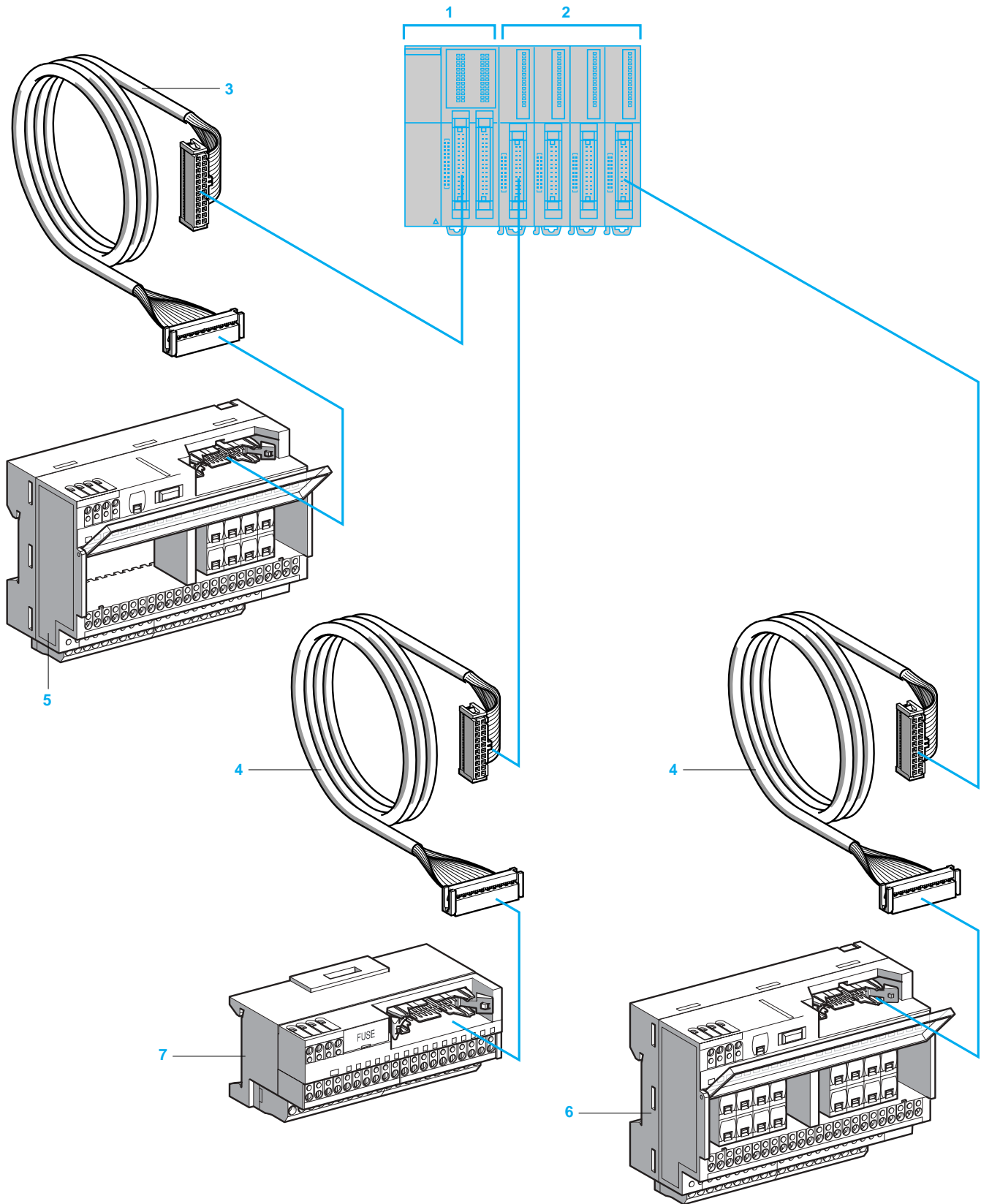

## Presentation (continued)

- 1 Modular base controller with 26-way HE 10 connectors. The modular sizes available are 20 or 40 I/O.
- 2 Input and output modules with 20-way HE 10 connectors. The modular sizes available are 16 or 32 I/O.
- 3 Cable (ABF T26B●●0) equipped with a 26-way HE 10 connector at each end. This cable is available in 0.5, 1 and 2 metre lengths (AWG 28/0.08 mm<sup>2</sup>).
- 4 Cable (ABF T20E●●0) equipped with a 20-way HE 10 connector at each end. This cable is available in 0.5, 1, 2 and 3 metre lengths (AWG 28/0.08 mm<sup>2</sup>).
- 5 20 channel sub-base (ABE 7B20MPN2● or ABE 7B20MR20) for modular base controllers.
- 6 16 channel sub-base (ABE 7E16SPN22 or ABE 7E16SRM20) for output extension modules.
- 7 16 channel sub-base (ABE 7E16EPN20 or ABE 7E16SPN20) for input or output extension modules.

## Compatibility with modular base controllers and I/O modules

	Modular base controllers	Discrete I/O modules	
	Inputs/outputs	Inputs	Outputs
<b>Incorporated in Twido programmable controllers</b>	<b>TWD LMDA 20DTK</b> (12 I/8 O) <b>TWD LMDA 40DTK</b> (24 I/16 O)	<b>TWD DDI 16DK</b> (16 I) <b>TWD DDI 32DK</b> (32 I)	<b>TWD DDO 16TK</b> (16 O) <b>TWD DDO 32TK</b> (32 O)
<b>Terminal block types</b>	HE 10 connector, 26-way	HE 10 connector, 20-way	
<b>Connection to Twido programmable controller</b>	<b>ABF T26B●●0</b> (HE 10, 26-way)	<b>ABF T20E●●0</b> (HE 10, 20-way)	

### Passive connection sub-bases

20 channels	<b>ABE 7B20MPN2●</b>				
16 channels	<b>ABE 7E16EPN20</b>				
	<b>ABE 7E16SPN2●</b>				

### Output adapter bases

20 channels	<b>ABE 7B20MRM20</b>				
16 channels	<b>ABE 7E16SRM20</b>				

Environment characteristics				
Product certifications			UL, CSA	
Degree of protection	Conforming to IEC 60529		IP 2X	
Protective treatment			"TC"	
Resistance to incandescent wire	Conforming to IEC 60695-2-11	°C	750: extinction < 30 s	
Shock resistance	Conforming to IEC 60068-2-27	ms	11 (half sine wave) 15 gn (acceleration)	
Vibration resistance	Conforming to IEC 60068-2-6	Hz	10...150 2 gn (acceleration)	
Resistance to electrostatic discharge	Conforming to IEC 61000-4-2		Level 3	
Resistance to radiated fields	Conforming to IEC 61000-4-3	V/m	10 (80 MHz to 2 GHz), level 3	
Immunity to fast transient currents	Conforming to IEC 61000-4-4		Level 3	
Surge withstand	Conforming to IEC 61000-4-5	µs	1.2/50 - 8/20	
Ambient air temperature	Conforming to IEC 61131-2	°C	Operation: - 5...+ 60	
		°C	Storage: - 40...+ 80	
Dielectric test voltage (for 1 minute)	Terminals/mounting rails	kV	2	
Overvoltage category	Conforming to IEC 60664-1		Category II	
Degree of pollution	Conforming to IEC 60664-1		2	
Mounting	Conforming to IEC 60715		On standard  rail, height 15 mm, width 35 mm	
Connection	Flexible cable without cable end	mm <sup>2</sup>	1 x 0.14...2.5	–
		AWG	1 x 26...14	–
	Flexible cable with cable end	mm <sup>2</sup>	1 x 0.09...1.5	2 x 0.09...0.75
		AWG	1 x 28...16	2 x 28...20
	Solid cable	mm <sup>2</sup>	1 x 0.14...2.5	2 x 0.12...1.5
		AWG	1 x 26...12	2 x 28...16
Tightening torque		Nm	0.6 (with 3.5 mm flat screwdriver)	

Supply characteristics (controller side)			
Supply voltage	Conforming to IEC 61131-2	~ V	19...30 (Un = 24)
Maximum supply current per sub-base		~ A	2
Voltage drop on supply fuse		~ V	0.3
Supply overload and short-circuit protection by quick-blow fuse (included)		A	2

Characteristics of the control circuit for 1 channel (sensor/controller side)						
Sub-base type	ABE 7	Passive connection sub-bases for discrete signals			Connection sub-bases with soldered relays	
		B20MPN2●	E16EPN20	E16SPN2●	B20MRM20	E16SRM20
Number of channels	Passive input	12	16	–	12	–
	Passive output	8	–	16	–	–
	Solid state output	–	–	–	2	–
	Relay output	–	–	–	6	16
Rated voltage Ue		~ V	24			
Min/max voltage	Conforming to IEC 61131-2	~ V	20.4/26.4	20.4/28.8	19/30	
Internal current per channel at Ue	Passive input	mA	– (3.2 for ABE 7 B20MPN22)	–		
	Passive output	mA	– (3.2 for ABE 7 B20MPN22)	– (3.2 for ABE 7 E16SPN22)		
	Solid state output	mA	–	–	4.5	–
	Relay output	mA	–	–	9	–
State 1 guaranteed	Solid state output	V/mA	–	–	16/5.5	–
	Relay output	V	–	–	16.8	–
State 0 guaranteed	Solid state output	V/mA	–	–	10/0.4	–
	Relay output	V	–	–	2	–
Conformity	Conforming to IEC 61131-2		Type 1	Type 1	–	Type 1

Output circuit characteristics (preactuator side)								
Sub-base type		ABE 7	Passive connection sub-bases for discrete signals			Connection sub-bases with soldered relays		
			B20MPN2●	E16EPN20	E16SPN2●	B20MRM20	E16SRM20	
Number of channels	Passive output		8	–	16	–	–	
	Solid state output		–	–	–	2	–	
	Relay output		–	–	–	6	16	
Contact arrangement			–				1 N/O relay	
Rated voltage at Ue	Passive output	$\text{--- V}$	24	–			–	
	Solid state output	$\text{--- V}$	–	–			24	–
	Relay output	$\text{--- V}$	–	–			5...30	
		$\sim \text{V}$	–	–			110...250	
Current switched per I/O channel	Passive input/output	<b>mA</b>	15/300	15/–	–/100	15/–	–	
	Solid state output	<b>A</b>	–	–			2	–
	Relay output	<b>A</b>	–	–			3	
Maximum current per common	Passive output	<b>A</b>	2	–	1.6	–		
	Solid state output	<b>A</b>	–	–			4	–
	Relay output	<b>A</b>	–	–			10	5
Rated operational current (60 °C max) (for 500 000 operations)	DC 12	<b>A</b>	–	–			2/3	–/3
	DC 13	<b>A</b>	–	–			2/0.5	–/0.5
	AC 12, relay	<b>A</b>	–	–			2	
	AC 15, relay	<b>A</b>	–	–			0.4	
Minimum current		<b>mA</b>	–	–			1/100	–/100
Rated insulation voltage		<b>V</b>	Not isolated			300		
Maximum response time	From state 0 to state 1	Solid state output	<b>ms</b>	–			0.01	–
		Relay output	<b>ms</b>	–			5	5
	From state 1 to state 0	Solid state output	<b>ms</b>	–			0.4	–
		Relay output	<b>ms</b>	–			2.5	2.5
Channel fuse protection		<b>mA</b>	– (315 for ABE 7 B20MPN22)	–	– (125 for ABE 7 E16SPN22)	–		

Other characteristics (at ambient temperature of 20 °C)								
Sub-base type		ABE 7	Passive connection sub-bases for discrete signals			Connection sub-bases with soldered relays		
			B20MPN2●	E16EPN20	E16SPN2●	B20MRM20	E16SRM20	
Permissible leakage current without illuminating the channel LED			<b>mA</b>	– (1.5 for ABE 7 B20MPN22)	–	– (1.5 for ABE 7 E16SPN22)	–	
Rated impulse withstand voltage (1.2/50)	Solid state output		<b>kV</b>	–			2.5	–
	Relay output		<b>kV</b>	–			6	
Switching frequency	Solid state output		<b>Hz</b>	–			300	–
	Relay output		<b>Hz</b>	–			20	
Mechanical durability		In millions of operating cycles		–			20	

**Curves for determining cable type and length according to the current**

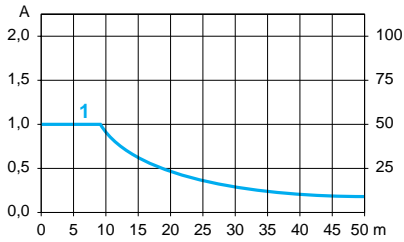

8 Cables ABF T2●●●●● c.s.a. 0.08 mm<sup>2</sup> (AWG 28)

**Temperature derating curves**

**ABE E11SRM20, ABE 7E16SRM20**

6 electromechanical relay outputs

**ABE 7B20MR20**

2 solid state outputs

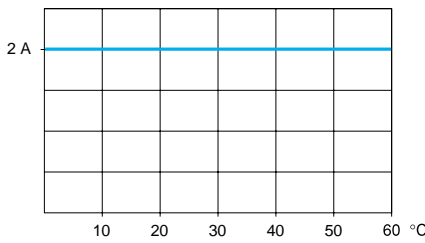
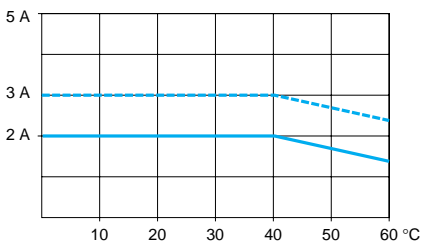

— 100 % of channels used  
- - - 50 % of channels used



## Electrical durability (in millions of operating cycles, conforming to IEC 60947-5-1)

### ABE 7B20MRM20 and ABE 7E16SRM20

#### d.c. loads

DC 12 curves (1)

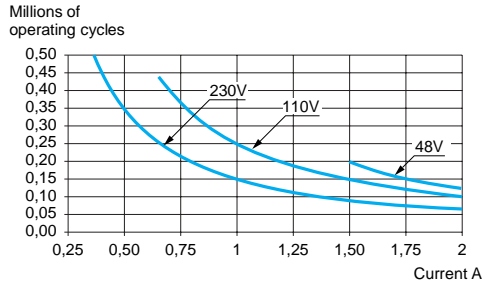

DC 13 curves (2)

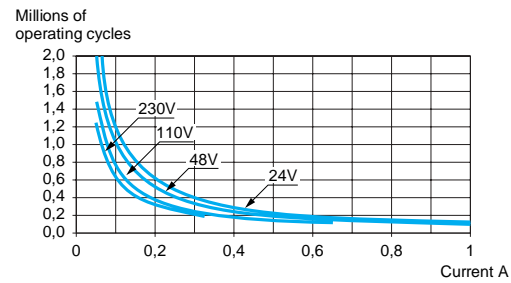

#### a.c. loads

AC 12 curves (3)

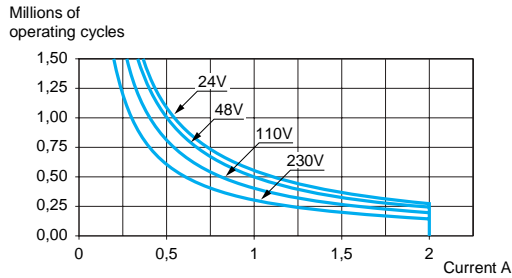

AC 14 curves (4)

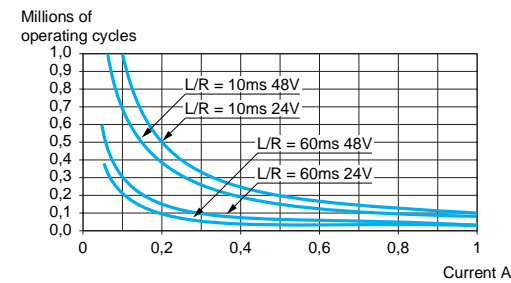

AC 15 curves (5)

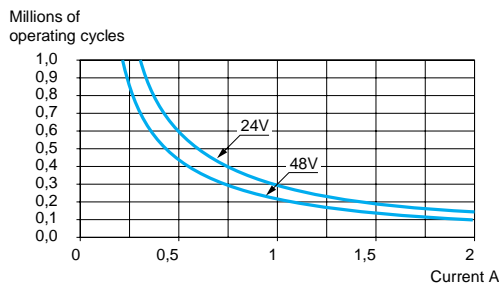

- (1) DC 12: control of resistive loads and of solid state loads isolated by optocoupler,  $L/R \leq 1$  ms.  
 (2) DC 13: control of electromagnets,  $L/R \leq 2 \times (U_e \times I_e)$  in ms,  $U_e$ : Rated operational voltage,  $I_e$ : rated operational current (with a protective diode on the load, DC12 curves must be used with a coefficient of 0.9 applied to the number in millions of operating cycles)  
 (3) AC 12: control of resistive loads and of solid state loads isolated by optocoupler,  $\cos \varphi \geq 0.9$ .  
 (4) AC 14: control of small electromagnetic loads  $\leq 72$  VA, make:  $\cos \varphi = 0.3$ , break:  $\cos \varphi = 0.3$ .  
 (5) AC 15: control of electromagnetic loads  $> 72$  VA, make:  $\cos \varphi = 0.7$ , break:  $\cos \varphi = 0.4$ .

# IP 20 distributed inputs/outputs

Advantys, Telefast® pre-wired system for I/O modules  
Connection sub-bases



ABE 7B20MPN20

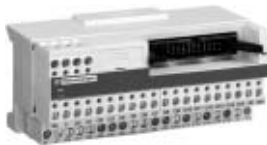

ABE 7E16EPN20



ABE 7E16SRM20

## References

### For Twido modular base controllers

Number of I/O	Number, type of input	Number, type of output	Compatibility	LED per channel	Fuse	Reference	Weight kg
20	12, sink --- 24 V	8, source --- 24 V	TWD LMDA20DTK/ LMDA40DTK	No	No	ABE 7B20MPN20	0.430
				Yes	Yes	ABE 7B20MPN22	0.430
	12, sink --- 24 V	2, source --- 24 V, 2 A and 6, relay --- 24/ ~ 250 V, 3 A	TWD LMDA20DTK/ LMDA40DTK	No	No	ABE 7B20MRM20	0.430

### For Twido extension modules

Number of inputs	Type of input	Compatibility	LED per channel	Fuse	Reference	Weight kg
16	Sink --- 24 V	TWD DDI16DK/ DDI32DK	No	No	ABE 7E16EPN20	0.430

Number of outputs	Type of output	Compatibility	LED per channel	Fuse	Reference	Weight kg
16	Source --- 24 V	TWD DDO16TK/ DDO32TK	No	No	ABE 7E16SPN20	0.450
			Yes	Yes	ABE 7E16SPN22	0.450
	Relay --- 24/~ 250 V, 3 A	TWD DDO16TK/ DDO32TK	No	No	ABE 7E16SRM20	0.430

### Connection cables for Twido modular base controllers

Type of signal	Compatibility	Type of connection		Gauge/ C.s.a.	Length (1)	Reference	Weight kg	
		Twido side	Telefast side					
Discrete inputs/ outputs	TWD LMDA20DTK/ LMDA40DTK	HE 10 26-way	HE 10 26-way	28/ 0.08	0.5	ABF T26B050	0.080	
					1.0	ABF T26B100	0.110	
					2.0	ABF T26B200	0.180	
		TWD DDI16DK/ DDI32DK/ DDO16TK/ DDO32TK	HE 10 20-way	HE 10 20-way	28/ 0.08	0.5	ABF T20E050	0.060
						1.0	ABF T20E100	0.080
						2.0	ABF T20E200	0.140

### Accessories

Description	Number of shunted terminals	Characteristics	Sold in lots of	Unit reference	Weight kg
Optional snap-on terminal blocks	20	–	5	ABE 7BV20	0.060
	12 + 8	–	5	ABE 7BV20TB	0.060
Quick-blow fuses 5 x 20, 250 V, UL	–	0.125 A	10	ABE 7FU012	0.010
		0.315 A	10	ABE 7FU030	0.010
		1 A	10	ABE 7FU100	0.010
		2 A	10	ABE 7FU200	0.010

(1) For lengths > 2 m, please contact us.

**References (continued)**

Separate components						
Description	Type	Compatibility	Reference	Weight		
<b>Connectors</b> (sold in lots of 5)	HE 10 female 26-way	TWD LMDA20DTK/ LMDA40DTK	<b>TWD FCN2K26</b>	—		
	HE 10 female 20-way	TWD DDI16DK/ DDI32DK/ DDO16TK/ DDO32TK	<b>TWD FCN2K20</b>	—		
<b>Screw terminal blocks</b> (sold in lots of 2)	10-way	TWD DDI●DT/DAI8DT/ DDO8●T/DRA●RT	<b>TWD FBT2T10</b>	—		
	11-way	TWD DMM8DRT/ AMI●●T/ARI8HT	<b>TWD FTB2T11</b>	—		

Description	Compatibility	Type of connection		Gauge/ C.s.a.	Length	Reference	Weight
		Twido side	Other end				
				AWG/mm <sup>2</sup>	m	kg	
<b>Cables for discrete I/O</b>	TWD LMDA20DTK/ LMDA40DTK	HE 10	Bare wires	22/ 0.035	3.0	<b>TWD FCW30M</b>	0.405
		26-way			5.0	<b>TWD FCW50M</b>	0.670
	TWD DDI16DK/ DDI32DK/ DDO16TK/ DDO32TK	HE 10	Bare wires	22/ 0.035	3.0	<b>TWD FCW30K</b>	0.405
		20-way			5.0	<b>TWD FCW50K</b>	0.670
<b>Pre-formed cable, rolled</b>	20 conductors	—	—	28/ 0.08	20.0	<b>ABF C20R200</b>	1.310

**Dimensions**

**ABE 7B20MPN20, ABE 7B20MPN22, ABE 7B20MRM20, ABE 7E16SPN22, ABE 7E16SRM20**

Mounting on 35 mm  rail

Screw fixing (retractable lugs)

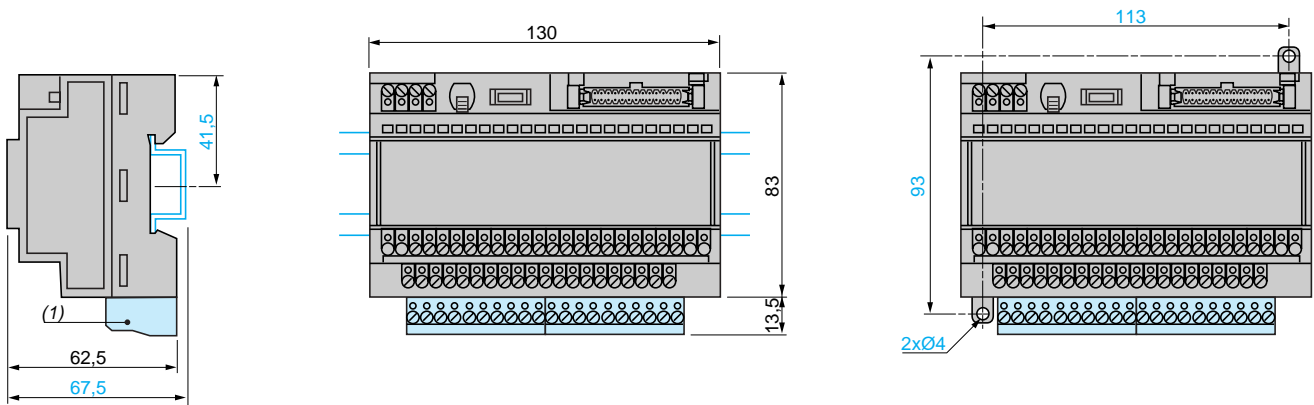

(1) ABE 7BV20, ABE 7BV20TB.

**ABE 7E16EPN20, ABE 7E16SPN20**

Mounting on 35 mm  rail

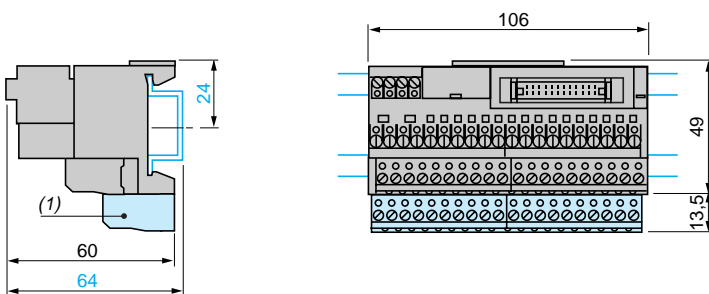

(1) ABE 7BV20, ABE 7BV20TB.



## ABE 7B20MRM20

HE10, 26-way

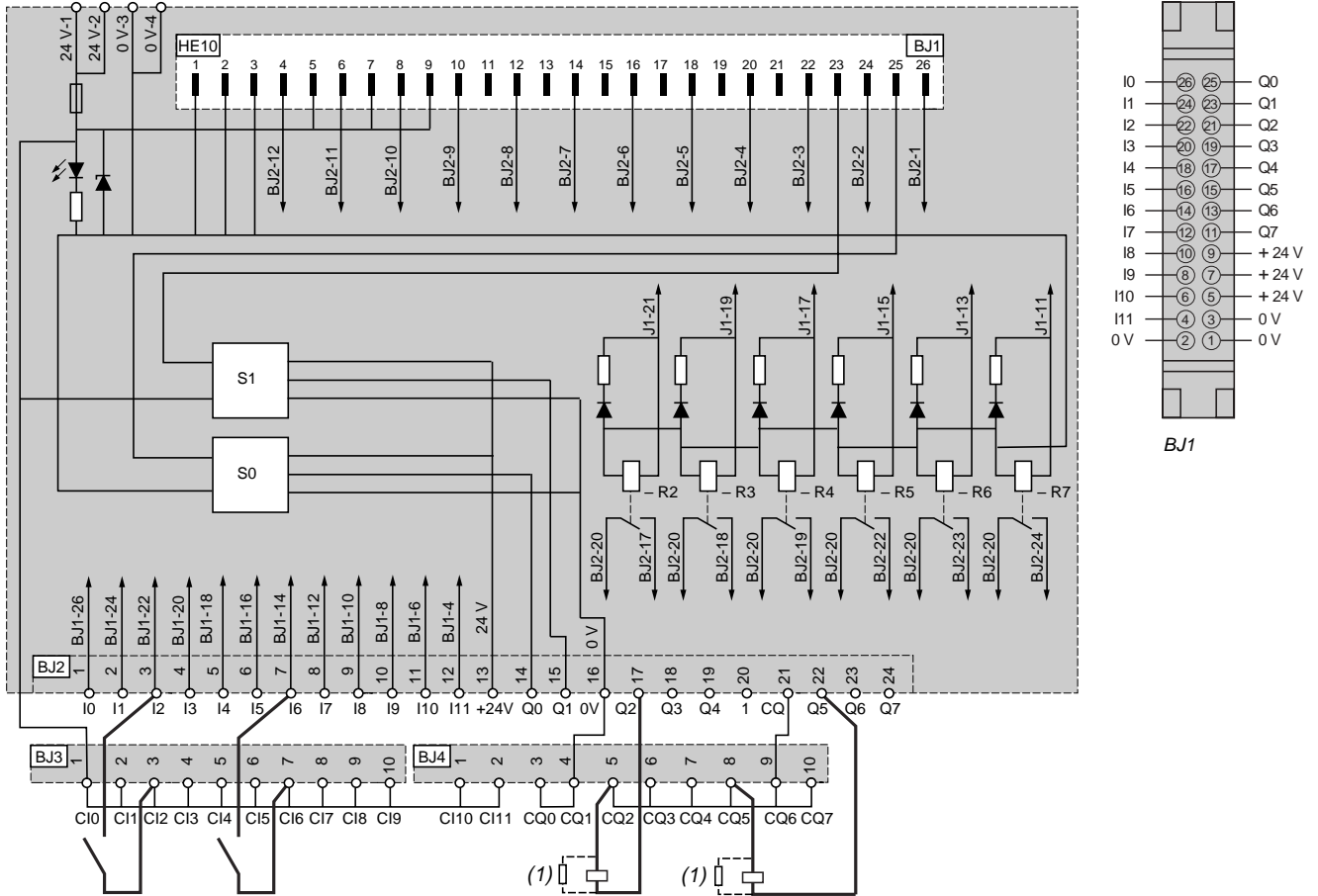

(1) Example of output connections.  
When connecting an inductive load, include a diode or a varistor.

## ABE 7E16EPN20

HE10, 20-way

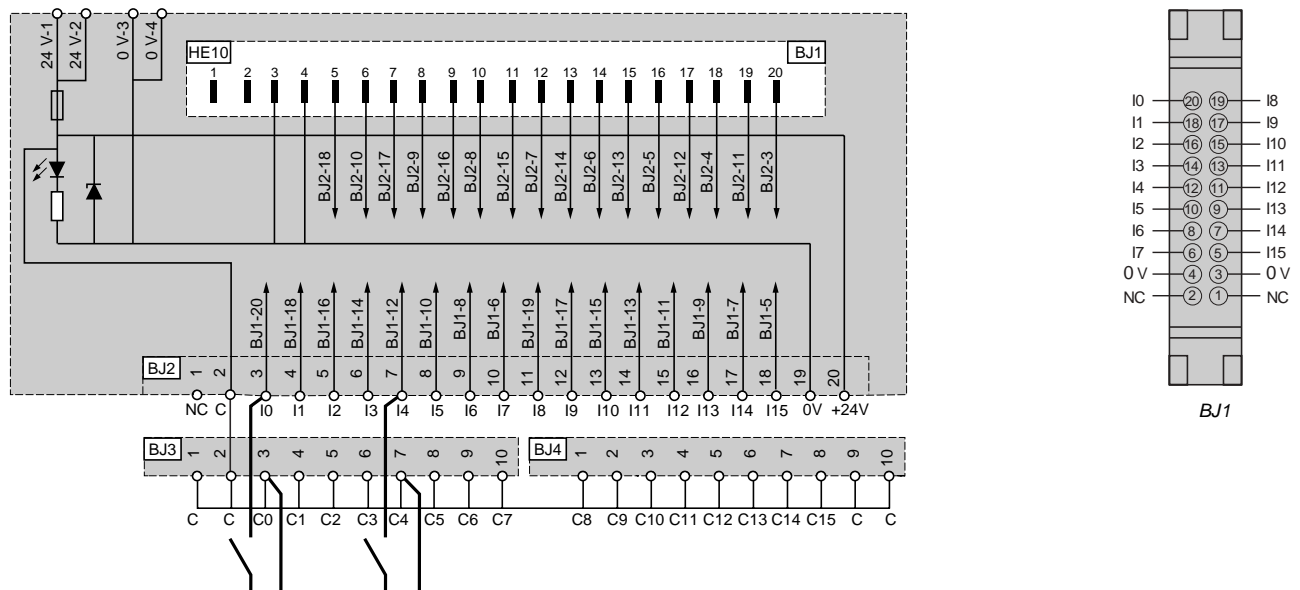

**ABE 7E16SPN20**

HE10, 20-way

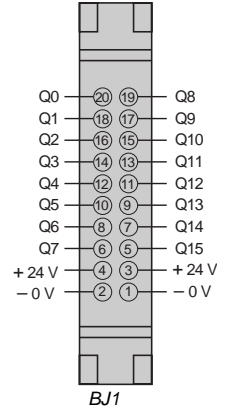
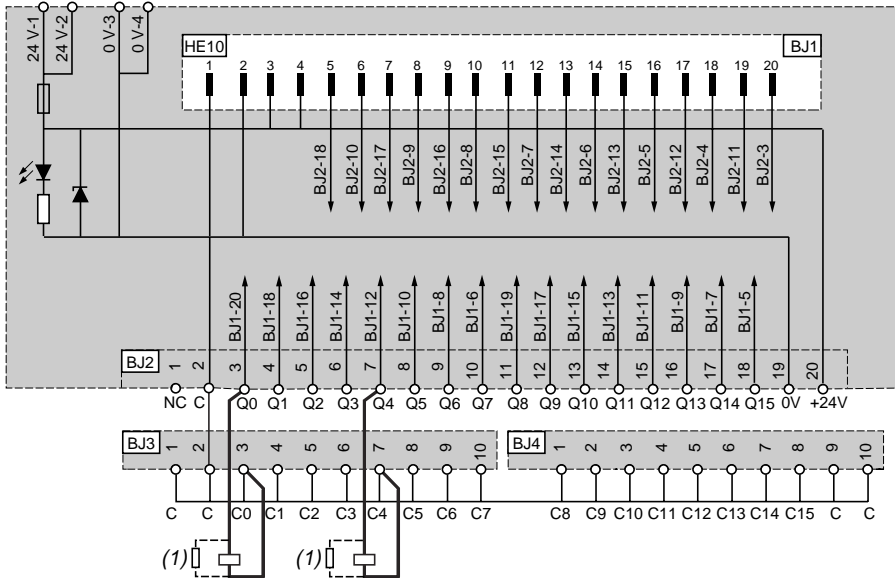

**ABE 7E16SPN22**

HE10, 20-way

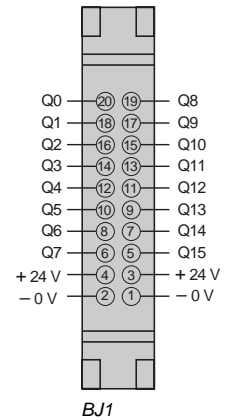
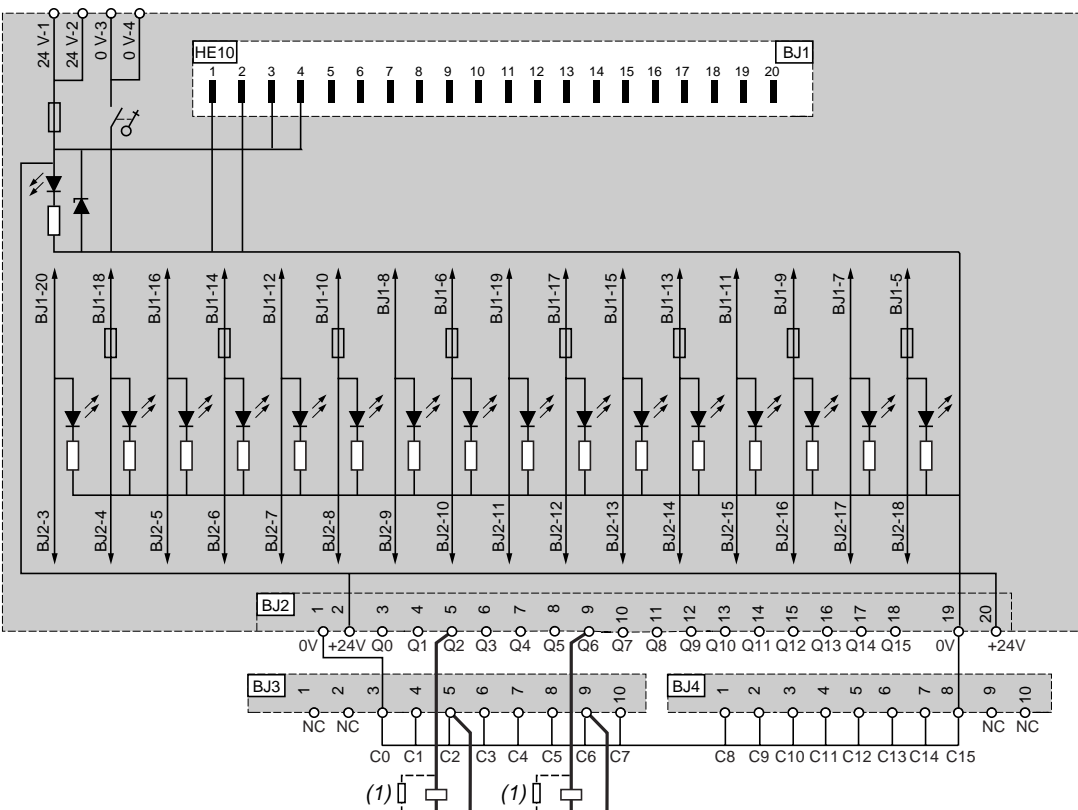

(1) Example of output connections.  
When connecting an inductive load, include a diode or a varistor.

ABE 7E16SRM20

HE10, 20-way

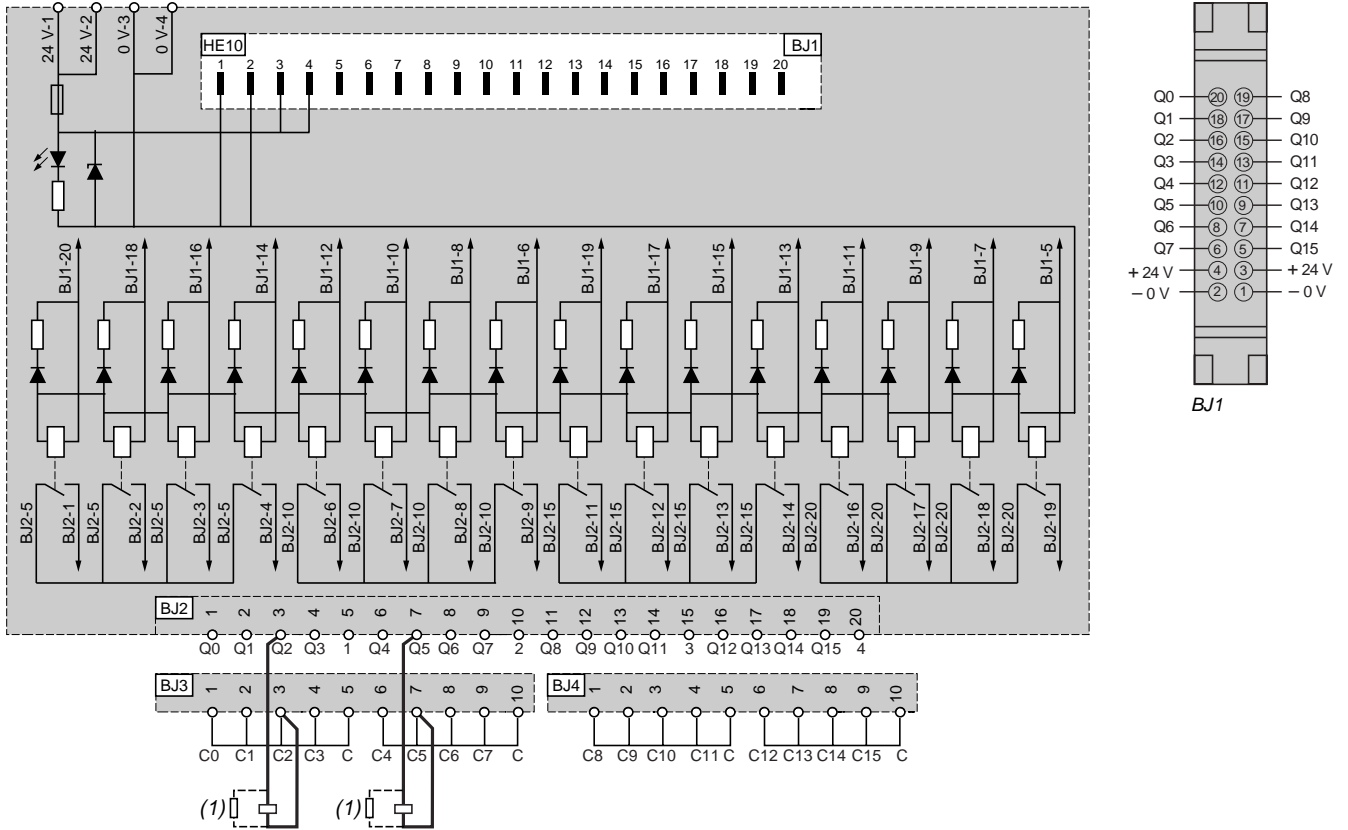

(1) Example of output connections.  
When connecting an inductive load, include a diode or a varistor.





# The efficiency of Telemecanique branded *solutions*

Used in combination, Telemecanique products provide quality solutions, meeting all your **Automation & Control** applications requirements.



## A worldwide presence

### Constantly available

- More than 5 000 points of sale in 130 countries.
- You can be sure to find the range of products that are right for you and which complies fully with the standards in the country where they are used.

### Technical assistance wherever you are

- Our technicians are at your disposal to assist you in finding the optimum solution for your particular needs.
- Schneider Electric provides you with all necessary technical assistance, throughout the world.



### Schneider Electric Industries SAS

Head Office  
89, bd Franklin Roosevelt  
92506 Rueil-Malmaison Cedex  
France

[www.schneider-electric.com](http://www.schneider-electric.com)  
[www.telemecanique.com](http://www.telemecanique.com)

Due to evolution of standards and equipment, the characteristics indicated in texts and images of this document do not constitute a commitment on our part without confirmation.

Design: Schneider Electric  
Photos: Schneider Electric  
Printed by:

*Simply Smart !*

DIA3ED2050404EN